

Connecting Science and the Musical Arts in Teaching Tone Quality:  
Integrating Helmholtz Motion and Master Violin Teachers' Pedagogies

A dissertation submitted in partial fulfillment of the requirements for the degree of  
Doctor of Arts at George Mason University

By

Cheri D. Collins  
Master of Arts  
George Mason University, 1996  
Bachelor of Music  
Manhattan School of Music, 1976

Director: Dr. James Gardner  
Department of Music

Spring Semester 2009  
George Mason University  
Fairfax, VA

UMI Number: 3367052

Copyright 2009 by  
Collins, Cheri D.

All rights reserved

#### INFORMATION TO USERS

The quality of this reproduction is dependent upon the quality of the copy submitted. Broken or indistinct print, colored or poor quality illustrations and photographs, print bleed-through, substandard margins, and improper alignment can adversely affect reproduction.

In the unlikely event that the author did not send a complete manuscript and there are missing pages, these will be noted. Also, if unauthorized copyright material had to be removed, a note will indicate the deletion.

UMI<sup>®</sup>

---

UMI Microform 3367052  
Copyright 2009 by ProQuest LLC  
All rights reserved. This microform edition is protected against  
unauthorized copying under Title 17, United States Code.

---

ProQuest LLC  
789 East Eisenhower Parkway  
P.O. Box 1346  
Ann Arbor, MI 48106-1346

Copyright 2009 Cheri D. Collins  
All Rights Reserved

## DEDICATION

This is dedicated to my sister Sandi and my HBF Misi.

## ACKNOWLEDGEMENTS

I would like to thank Dr. James Gardner for his guidance and steadfast support throughout this project. My committee members Dr. Victory Salmon, Dr. Linda Apple Monson, and Maestro Anthony Maiello, for their inspiration and unwavering confidence in my abilities as a teacher and musician. Dr. Keith Monson, for eagerly sharing his comprehensive knowledge of Physics. My friends and colleagues Bette Gawinski, Deanna Kringle, and Trisha Trillet for experimenting with the *New Method* in their classrooms, and providing me with valuable feedback.

## TABLE OF CONTENTS

	Page
List of Figures . . . . .	viii
Abstract . . . . .	ix
1. Introduction . . . . .	1
2. The Problem . . . . .	3
Significance and Need for the Study . . . . .	3
Proposed Research Questions . . . . .	6
Delimitations and Limitations of the Study . . . . .	7
Definition of Terms . . . . .	7
3. Research Procedures . . . . .	12
Research Methodology . . . . .	12
Specific Procedures and Data Collection . . . . .	12
Integration and Application . . . . .	13
4. Review of the Literature: Science and Art . . . . .	14
The Cremona Violinmakers . . . . .	15
Primary Studies in the Physics of Strings . . . . .	16
Contemporary Violin Makers Copying Cremona . . . . .	17
Celebrated Scientists . . . . .	18
Ernst Florens Friedrich Chladni . . . . .	19
Hermann von Helmholtz . . . . .	24
John C. Schelleng . . . . .	35
Anders Askenfelt and Erik Jansson . . . . .	37
Chandrasekhara Venkata Raman . . . . .	39
New Research . . . . .	44
Joseph Paradiso and Neil Gershenfeld . . . . .	44
Tracy Kwei-Liang Ho . . . . .	46
Charles Nichols . . . . .	48
Diane Young . . . . .	51
Alfonso Perez . . . . .	52
Tone Quality . . . . .	53
George Bissinger . . . . .	53
Jürgen Meyer . . . . .	55
Heinrich Dünwald . . . . .	56
Eric Jansson . . . . .	58
Modern Swedish Violins . . . . .	58
American Cello Congress . . . . .	59

5. Review of the Literature: Master Teachers' Tone Production Pedagogy . . . . .	60
Carl Flesch . . . . .	61
Ivan Galamian . . . . .	68
Robert Gerle . . . . .	73
Simon Fischer . . . . .	81
Widely Used Approaches to Teaching Tone-Production . . . . .	87
Strictly Strings . . . . .	88
Superstart: Basic Skills and Pieces for Beginners. . . . .	89
Essential Elements 2000 . . . . .	90
New Directions for Strings. . . . .	90
6. Summary and Synthesis . . . . .	98
Mixed Message Number 1: "Make a Big Beautiful Tone" . . . . .	96
Mixed Message Number 2: "Big Bows for a Big Sound" . . . . .	100
Mixed Message Number 3: "Get a Better Quality Instrument to Improve Tone" . . . . .	101
The New Method . . . . .	103
Applying Physics to Teaching Good Tone-Production . . . . .	104
Recalibration of the Ear . . . . .	104
Re-Balance of Components: Pressure, Speed, and Contact point . . . . .	106
Instructional Vocabulary . . . . .	106
Drills and Exercises . . . . .	107
7. Summary — Conclusion . . . . .	108
Proposed Future Research . . . . .	111
Appendix A: Application . . . . .	113
Introduction and Vocabulary . . . . .	115
Introducing the Helmholtz Motion: Exercise I . . . . .	117
Practice Exercise I: Learning to Play with Helmholtz Motion . . . . .	117
Bow Pressure: Exercises II—III . . . . .	120
Practice Exercise II: Silent Push-Ups . . . . .	120
Practice Exercise III: Move the String without Making a Sound. . . . .	121
Re-Calibrating the Ear: Exercise IV . . . . .	121
Practice Exercise IV: Desensitizing the Ear . . . . .	122
Bow Speed: Exercises V—IX . . . . .	123
Practice Exercise V: Counting Aloud with a Steady Beat . . . . .	124
Practice Exercise VI: How High Can We Count? . . . . .	125
Practice Exercise VII: Varying Bow Speeds (Advanced) . . . . .	126
Practice Exercise VIII: Different Length Notes — Playing All with Whole Bows . . . . .	126
Practice Exercise IX: Variations in Bow Speed Using Slurs . . . . .	127
Contact Point: Exercises X—XI. . . . .	128
Practice Exercise X: Tour of Contact Point 5 and 1. . . . .	130
Practice Exercise XI: Rhythms on Each Contact Point (Advanced). . . . .	131

Contact Point Imagery: Exercise XII . . . . .	132
Practice Exercise XII: Adding Imagery . . . . .	134
Additional Exercises: Exercises XIII — XIV . . . . .	135
Practice Exercise XIII: Feel the Resistance . . . . .	135
Practice Exercise XIV: The Anomaly of Strings Vibrating . . . . .	136
Applying Contact Point Pedagogy . . . . .	139
Appendix B: Useful Websites . . . . .	141
Selected Bibliography . . . . .	144

## LIST OF FIGURES

Figure	Page
4.01 Ernest Chladni’s Vibrational Modes . . . . .	20
4.02 First Five Signature Modes are the Same on All Violins. . . . .	22
4.03 Mode Tuning For the Violinmaker . . . . .	23
4.04 The Helmholtz Motion. . . . .	26
4.05 Bowed String Motion . . . . .	27
4.06 What the Player Sees. . . . .	29
4.07 The “Kink” called Helmholtz Motion . . . . .	30
4.08 Double Kink in the Helmholtz Motion . . . . .	30
4.09 Helmholtz Motion and Double-Slip. . . . .	32
4.10 Sympathetic Resonance — The Form of Vibration . . . . .	34
4.11 The Schelleng Diagram . . . . .	37
4.12 Measurement of the Bowing Parameters . . . . .	38
4.13 Interactions between Bow Force, Contact Point, Bow Velocity, and Bow Positions . . . . .	42
4.14 Range of Variation for the Bowing Parameters . . . . .	43
4.15 Cellist Yo Yo Performing in Concert on the Hypercello . . . . .	45
4.16 Hypercello Bow . . . . .	46
4.17 The v-Bow, version 2 . . . . .	50
4.18 Five Signature Modes in the Violin . . . . .	54
4.19 Heinrich Dünwald Experiment . . . . .	57
5.01 Carl Flesch Point of Contact . . . . .	64
5.02 Robert Gerle: Bowing Elements in Varying Proportions. . . . .	77
5.03a Positive Pressure . . . . .	78
5.03b Negative Pressure. . . . .	79
5.04 Simon Fischer — Soundpoint . . . . .	86
5.05 New Directions for Strings: Bowing on the Instrument . . . . .	92
5.06 Good Sound, Big Tone . . . . .	94
A.01 Blackboard Drawing of the Helmholtz Motion. . . . .	118
A.02 Simple Model of Contact Points . . . . .	129
A.03 Contact Point Imagery: Maintaining Constant Pressure and Speed . . . . .	133

## ABSTRACT

### CONNECTING SCIENCE AND THE MUSICAL ARTS IN TEACHING TONE QUALITY: INTEGRATING HELMHOLTZ MOTION AND MASTER VIOLIN TEACHERS' PEDAGOGIES

Cheri D. Collins, D.A.

George Mason University, 2009

Dissertation Director: Dr. James Gardner

Is it possible for students to achieve better tone quality from even their factory-made violins? All violins, regardless of cost, have a common capacity for good tone in certain frequencies. These signature modes outline the first position range of a violin (196-600 hertz). To activate this basic capacity of all violins, the string must fully vibrate. To accomplish this the bow must be pulled across the string with enough pressure (relative to its speed and contact point) for the horsehairs to catch. This friction permits the string to vibrate in Helmholtz Motion, which produces a corner that travels along the edge of the string between the bridge and the nut. Creating this corner is the most fundamental technique for achieving good tone.

The findings of celebrated scientists Ernest Chladni, Hermann von Helmholtz, and John Schelleng will be discussed and the tone-production pedagogy of master teachers Carl

Flesch, Ivan Galamian, Robert Gerle, and Simon Fischer will be investigated. Important connections between the insights of these scientists and master teachers are evident.

Integrating science and art can provide teachers with a better understanding of the characteristics of good tone. This can help their students achieve the best possible sound from their instruments.

In the private studio the master teacher may not use the words “Helmholtz Motion.” Yet through modeling and listening students are able to understand and create a quality tone. Music teachers without experience in string performance may be assigned to teach strings in classroom and ensembles settings. As a result modeling good tone is not always possible. However, all teachers and conductors can understand the fundamental behavior of string vibration and adapt their instruction strategies towards student success. Better tonal quality for any string instrument is ultimately achieved. Mastery and use of the Helmholtz Motion benefits teachers and students alike. Simple practice exercises for teaching and conducting, based on student discovery rather than modeling, are presented in Appendix A: Application. This approach to teaching good tone can be applied successfully in all string settings and levels.

## CHAPTER ONE

### INTRODUCTION

The traditional approach to teaching tone-production is through teacher modeling. However, for a variety of reasons, many string positions are filled by teachers with a non-string professional background. Therefore, another approach to teaching good tone-production is necessary. Integrating science and art can provide teachers with a better understanding of the characteristics of good tone, which can help their students achieve the best possible sound quality from their violins. Once teachers have a systematic approach to teaching a good tone that does not exclusively depend on modeling, the bow can be introduced with more confidence and without delay. Learning the technique of good sound-production can give students the chance to achieve greater success on their instrument.

Anders Askenfelt, scientist from KTH, Royal Institute of Technology, states that, “a violin player selects the bowing parameters with high accuracy, consciously and unconsciously, using their ears.”<sup>1</sup> He also notes that the bow-bridge distance, the amount

---

<sup>1</sup> Anders Askenfelt, “Measurement of the Bowing Parameters in Violin Playing,” *Journal of the Acoustical Society of America* 84 (November 1988): 163, <http://www.speech.kth.se/qpsr> (accessed September 20, 2007).

of bow pressure, and the bow's velocity are not notated in a musical score. Therefore, it is up to the player to determine the placement, pressure, and velocity of the bow with respect to what the composer asks musically.<sup>2</sup> There is much confusion about what is a good tone. Many violin students hear what is coming out of their instrument, close to their ear, and strive for "beautiful tone." The question then becomes, "Can good tone be identified when the instrument is so close to the ear?" Important research in this specific area suggests that the player's judgment is not reliable.<sup>3</sup>

Master violin teachers effectively teach tone-production in their studio principally through modeling. They have student match and copy what they hear from the teacher. Yet, the majority of students cannot benefit from nor afford this one-to-one traditional instructional approach. Therefore, it is important that classroom teachers and conductors have strategies and tools in place to teach good tone-production to their students; these resources should be effective and engage student learning through directed self-discovery. Modeling may be the perfect way to teach tone-production in a private studio, however, the classroom string teachers need an approach that does not exclusively depend on modeling.

---

<sup>2</sup> Askenfelt, "Measurement of Bowing Parameters," 163.

<sup>3</sup> Helmholtz, Hermann von. *On the Sensation of Tone as a Physiological Basis for the Theory of Music*, Tran. Alexander John Ellis, 4<sup>th</sup> ed. (New York: Longmans, Green, Doves, 1912).

## CHAPTER TWO

### THE PROBLEM

#### **Significance and Need for the Study**

One of the chief components of an effective music program is tone-production. Study and research is needed to understand and articulate how scientific evidence in tone-production can be more effectively incorporated into the classroom. Tone quality is often a primary measure used to differentiate between the accomplished violinist and the unskilled violinist. Present-day books aimed at teaching string students in a heterogeneous class setting do not provide a systematic method for teachers to incorporate tone quality in student instruction. Many books introduce the three components necessary for producing a quality tone; bow speed, bow pressure, and contact point. Although these components are incorporated into teaching basic dynamics, this can be confusing for the teachers who do not have a strings background. String programs at the college level are also impacted by this impediment. College professors teaching string pedagogy and lab strings, need to provide students with supplemental materials to enrich the existing books in the instruction of tone-production.

Producing good tone quality on the string instruments is linked to the Helmholtz Motion.<sup>1</sup> This refers to the behavior of a vibrating string, and is essential for producing a quality tone; the player's ability to generate the required friction between the bow and string engages and maintains the Helmholtz Motion. When the string is engaged in Helmholtz Motions, the amplitudes of the harmonics produced are vibrating at their widest, thus the best possible tone quality for the instrument can be achieved.

Books for teaching strings in a heterogeneous setting do not include a method for Helmholtz Motion, the most fundamental property of tone-production. All string instruments produce a tone when the bow travels across a string, however, there is one important distinction: the quality of tone is "determined by the amplitudes of the harmonics which are present."<sup>2</sup> If the note being played is vibrating in Helmholtz Motion, then the harmonics produced will be at their widest and strongest possible. Helmholtz Motion is achieved when the bow is pulled across the string with enough friction for the horsehairs to catch. To generate enough friction and engage Helmholtz Motion over an extended period of time, the bow needs to be slow and exerted with even pressure to allow the horsehairs adhesion to the string, consequently increasing the amplitudes of the harmonics in that note. This is an essential and fundamental bow

---

<sup>1</sup> Helmholtz, 83.

<sup>2</sup> James Beament, "The Vibration of Strings," Chapter 2, in *The Violin Explained: Components, Mechanism and Sound*, (England: Oxford University Press, 2000), 10.

technique that needs to occur to achieve a quality tone, and upon which all dynamic variations are built.

Currently, the principal focus of discussion within the classroom is often directed toward left-hand techniques, including vital concepts such as intonation and dexterity. One reason for this, according to master teacher Carl Flesch, is that left-hand technique is “more concrete and mechanical,” and therefore, straightforward and unambiguous adjustments can be made to fix these problems.<sup>3</sup> Unfortunately, when bow technique is ignored in the area of good tone-production, less mature string sections are achieved and sound, “lukewarm, watery, uniformity, and minus all characteristic shadings.”<sup>4</sup>

Insights from the physicists of sound (acoustics) can provide teachers with a clearer understanding of good tone quality. Visual aids provide great benefits to all levels of student learning. Teachers who can implement these elements will give their students an opportunity to understand what they hear as they are playing. Students might then discover what makes good tone and thereby greatly improve their sound quality.

Chapter Three is a discussion on the research procedures, and process of selecting materials to include in this study. Chapter Four, Review of the Literature: Science and Art, is an investigation of scientific research on the bowed string and acoustical research in tone-production. Published findings in how a string vibrates, (Helmholtz Motion) will

---

<sup>3</sup> Carl Flesch, *Problems of Tone Production in Violin Playing* (New York: Carl Fischer, 1934), 5.

<sup>4</sup> Flesch, *Problems of Tone*, 5.

be presented. A model developed by scientific research using bow pressure, bow speed, and bow contact points, (Schelleng Diagram) will provide a visual aid for good tone-production. In addition, relevant scientific research on the human perceptions of good tone will be interpreted. Chapter Five, Review of the Literature: Master Teachers' Tone Production Pedagogy is an investigation of the bowing pedagogies of tone-production of master teachers Carl Flesch, Ivan Galamian, Robert Gerle, and Simon Fischer. Included in this section is an investigation of the widely used books for a heterogeneous string setting, and their approach to teaching good tone-production. Chapter Six: Summary and Synthesis, is a discussion on how good tone-production might be more effectively taught by creating a synthesis between the acoustical findings and the master teacher's pedagogies on tone-production. A new method for teaching good tone is presented, using resources that are effective and engage student learning through directed self-discovery. Chapter Seven: Summary and Conclusion, includes suggestions for further research. Appendix A: Application, contains practice exercises, and a systematic approach to teaching the Helmholtz Motion in various string settings. Appendix B: Useful Websites, includes links to selected websites for music acoustic groups, violinmakers, and Simon Fischer tone-production master classes on YouTube.

### **Proposed Research Questions**

- 1) What is good tone-production?

- 2) How does the player produce good tone?
- 3) How can a teacher enhance student learning when teaching good tone-production?

### **Delimitations and Limitations of the Study**

The study focuses on strings, specifically violin and viola, though with minor adaptation extending to cello and string bass. Attention has been principally given to the elementary strings level, and with minor adaptations can extend to middle school, high school, and college level teaching.

The framework for this study is knowledge that is relevant for the string teacher, conductor, and college instructor. The published research collected and analyzed for comparison in this study is interpreted from a violinist's prospective.

### **Definitions of Terms**

- A note — the complete played sound of the simplest unit of music as produced by an instrument.
- Amplitude — how big a vibration is; the distance between the extreme movements of a vibration. This is commonly experience as the volume of the sound.
- Bow-bridge positions — see contact point.

- Bow horsehair — approximately 160 to 190 individual horsetail hairs are on each bow. Horses from the coldest climates are preferred, because of their coarseness.
- Bow stick — the part of the bow that is not the horsehair.
- Bridge — the piece of wood that elevates the strings above the fingerboard and transmits vibrations into the body of the instrument, and thereby to the air enclosed by the instrument.
- Color — the timbre of a musical sound, specifically the complexity of the sound wave.
- Contact point — the position of the bow in relationship to its distance from the bridge. Varying this distance while maintaining constant bow pressure and bow speed will produce a different timbre of sound. (also referred to as sounding point, soundpoint, point of contact, bow-bridge position, and lanes).
- Cycle — the repeated element of a regular vibration. The horsehair engages the kink through friction, the kink travels first to the bridge then under the horsehair towards the nut, when the kink returns to the bridge it is one cycle. Within the pitch A 440, the Helmholtz kink travels along the edge of the string 440 cycles per second.
- Double-Kink — the vibration in the string contains more than one Helmholtz corner in one cycle. This produces an airy, surface sounding tone as a result of the horsehairs not catching the string, thus Helmholtz Motion is lost.
- Double Stick-Slip — see double kink.

- Fingerboard — the ebony wood under the violin strings that the fingers of the left-hand use to make pitches.
- Frequency — the rate of vibration; the number of repetitions or cycles in a second. The frequency of violin open A is 440 cycles per second. (also referred to as 440 hertz).<sup>5</sup>
- Frog — the part of the bow that the right-hand uses to form the bow-hold.
- Harmonics — is any set of pure tones with frequencies in simple multiples of the lowest frequency. Harmonics are labeled sequentially: fundamental, second harmonic, third harmonic, etc.
- Helmholtz Motion — the kink formed in a fully vibrating string. The kink travels along the edge of the string between the bridge and the nut, one time per cycle. When open A string is bowed, the kink will travel between the bridge and the nut 440 times per second. (also referred to as Helmholtz corner, or Saw-Tooth motion).
- Hertz — the rate of vibration. One hertz means one cycle per second. Hertz is a unit of measurement of frequency or pitch.
- Heterogeneous — different instruments. Violins, viola, cello, and string bass players all in one class.
- Homogeneous — only one instrument. Class of just violins.

---

<sup>5</sup> Beament, 15.

- Lane — see contact point.
- Multiple level — elementary, middle school, high school, community college, university.
- Oscilloscope — a device with a small screen which displays the change of voltage of a signal connected to it on the y axis (up/down) against time on the x axis (left to right).<sup>6</sup>
- Pitch — the characteristic of a musical sound that enables the listener to refer to a scale of pitches.
- Pitch frequency — the fundamental and first harmonic in the overtone series.
- Point of contact — see contact point.
- Pressure — the physical exertion of a steady force applied to the bow when it travels on the string.
- Schelling Diagram — the maximum and minimum bow force on a particular contact point for production of Helmholtz Motion.
- Second harmonic — one octave above the sounding fundamental.
- Stick-Slip — the horsehairs alternately catch, then release the string. When this pattern develops, the string vibrates in Helmholtz Motion. When there is a break in this pattern (double-slip) Helmholtz Motion is lost. Also referred to as sticking- slipping motion.

---

<sup>6</sup> Beament, 9.

- Sounding point — see contact point.
- Soundpoint — see contact point.
- Timbre — the distinctive property of a complex sound. (also referred to as color).
- Tone production — the combination of a particular speed of bow with a particular amount of pressure on the bow both of which is dependent on the tension of the string at a particular distance between the bridge and the fingerboard.
- Weight — Amount of heaviness; force which gravity exerts upon the bow.

## CHAPTER THREE

### RESEARCH PROCEDURES

#### **Research Methodology**

This study uses an evaluative methodology applied to (1) source in published findings in acoustics specific to the vibrational characteristics of a bowed-string, and (2) violin pedagogical literature specific to tone-production. The selected master violin teachers are Carl Flesch, Ivan Galamian, Robert Gerle, and Simon Fischer. In addition, professional books used in multiple level string classes (elementary, secondary, and college) specific to tone-production are examined. No human subject review board approval is required in that this study is based on the examination of existing texts.

#### **Specific Procedures and Data Collection**

The purpose of this study is to provide connections between acoustical properties of good tone created on a bowed-string, and master violin teacher's tone-production pedagogies. Data collection is also based on the author's background as a professional violinist, private violin teacher, public school strings teacher, and conductor.

Review of the Literature chapters contain select scientific findings pertaining to the characteristics of a vibrating bowed-string, signature mode vibrations in the violin top plate, and listening trials used for comparisons of tone quality. Master violin teachers' pedagogies are analyzed to deduce common themes and methods for teaching tone-production. Review of the Literature chapters provides the background and focus for connecting science and art in teaching good tone quality in the multiple level heterogeneous string setting.

Sources from the Review of the Literature are analyzed regarding how they approach tone-production. The application for the material included for analysis is directed towards private teachers, schoolteachers, college teachers, and conductor at all levels.

### **Integration and Application**

Present-day books aimed at teaching strings in a classroom setting do not include an explanation of Helmholtz Motion, the most fundamental property of tone-production. Acoustical findings and master teacher pedagogies agree on the elements of good tone, but each has its own audience and vocabulary. Combining insights of acoustics and master teacher pedagogy can provide classroom teachers and conductors with strategies to create good tone-production. This can be effective and engage student learning through directed self-discovery.

## CHAPTER FOUR

### REVIEW OF THE LITERATURE: SCIENCE AND ART

What are the characteristics of tone and how is it produced on a bowed-string? This question has been the focus of scientific research through the ages. However, it was not until the twentieth century that scientists had the ability to measure the character of tone. Chapter Four is divided into three main sections. The first investigates scientist's earliest discoveries in acoustics, followed by subsequent acoustical research findings specific to how the bowed-string vibrates. The second investigates master teacher's pedagogy of producing a good tone. The third investigates recent pedagogical approaches to teaching tone-production in the classroom.

In the past thirty years, a more open conversation has developed between scientists and violinmakers.<sup>1</sup> Jim Woodhouse, an engineer at Cambridge University and “one of the most highly respected figures in violin acoustics,” believes that the shroud of secrecy is beginning to lift.<sup>2</sup> Woodhouse states that there is, “now a critical mass of

---

<sup>1</sup> Joseph Curtin, “Bridging the Divide,” *The Strad* 116, no. 1384 (August 2005): 44.

<sup>2</sup> Curtin, 44.

people [scientists and violinmakers] who are interested in exchanging ideas and that are moving everything forward.”<sup>3</sup>

## The Cremona Violinmakers

The study of the acoustics of string instruments is one of the most ancient mathematical sciences. The earliest contributor was Pythagoras around 550 BCE.<sup>4</sup> Master violin luthier and physicist, Martin Schleske lectured on the connections between the Arts and Sciences in his speech to the Association of German violinmakers in Wiesbaden, Germany in 2004.<sup>5</sup> The string instruments as we know them developed their optimal design in the works of the most famous seventeenth and eighteenth-century luthiers: Nicolo Amati (1596–1684), Giuseppe Guarneri (1698–1744), and Antonio Stradivari (1644–1737).<sup>6</sup> Schleske makes a comparison between the age of the scientific revolution and these craftsmen-artisans from Cremona, Italy.<sup>7</sup> He points out that anyone following the history of art and science would realize that violinmakers in that time were very familiar and receptive to the new discoveries happening in the world of science.

---

<sup>3</sup> Curtin, 44.

<sup>4</sup> Carl Huffman, “Pythagoras,” in *Stanford Encyclopedia of Philosophy*, ed. Edward N. Zalta, Stanford, CA: Center for the Study of Language and Information, 2005, <http://plato.stanford.edu/entries/pythagoras/> (accessed September 21, 2006).

<sup>5</sup> Martin Schleske, “Zeitgeist and Violinmaking: Milestones of Art and Science - a Brief Journey through Time,” lecture *100th Anniversary of the Founding of the Verband Deutscher Geigenbauer* (Association of German violinmakers.) Wiesbaden, Germany, (May 2004): 1, <http://www.schleske.de/index.php?id=38&type=123&L=2> (accessed August 10, 2008).

<sup>6</sup> Andrew Hsieh, “Cremona Revisited: The Science of Violin Making,” *Engineering & Science* no. 4 (April 2004): 29.

<sup>7</sup> Schleske, “Zeitgeist,” 1.

Those master luthiers' devotion to their craft makes the violin we know today, "a highly optimized acoustic system."<sup>8</sup>

### **Primary Studies in the Physics of Strings**

All are familiar with the famous seventeenth-century scientist, Isaac Newton. In 1672, Stradivari was in his twenties, while Isaac Newton was in the process of separating sunlight into spectral colors with a prism.<sup>9</sup> It is not difficult to imagine a possible dialogue taking place in the violinmakers' workshops using a word like tonal color, and indeed the term "color" is often used to describe various tonal qualities.<sup>10</sup>

In 1827, Ernst Florens Friedrich Chladni published the results of his research in the form of a treatise entitled, *Entdeckungen über die Theorie des Klangles* [*Discoveries Concerning the Theory of Sound*,] and is often referred to as the Father of Acoustics.<sup>11</sup> Hermann von Helmholtz published his masterpiece, *On the Sensation of Tone as a Physiological Basis for the Theory of Music*, in 1862 and his greatest contribution was his attempt to account for our perception of tone quality.<sup>12</sup> In 1973, John C. Schelleng published his Schelleng Diagram in "The Physics of the Bowed String," in *The Physics of Music*, which became the scientific model for showing how the position of the bow and

---

<sup>8</sup> Schleske, "Zeitgeist," 1.

<sup>9</sup> Schleske, "Zeitgeist," 1.

<sup>10</sup> Schleske, "Zeitgeist," 2.

<sup>11</sup> Hans-Jürgen Stöckmann, "Chladni Meets Napoleon," *Europe Physics Journal Special Topics* 124 (June 2007): 15-23.

<sup>12</sup> Helmholtz, 83.

how the motion of the string relates to sound production.<sup>13</sup> As a result of these discoveries, along with the advancement in technology, violinmakers have a much better understanding of the acoustical properties of the violin, including its playability.

Carleen Hutchins, a recipient of four honorary doctorates, is the foremost authority on violin acoustics. Hutchins co-founded the Catgut Acoustical Society in 1963, which is best known for their pioneering work in the development of scientific insights and their application to the construction of new and conventional instruments of the violin family.<sup>14</sup> Hutchins developed and built a series of violins ranging from very small, producing the highest frequencies, to very large, producing the lowest frequencies. She developed a set-up for assessing and altering the vibrational modes using Chladni's patterns, focusing on his first five, referred to today as "Signature Modes."<sup>15</sup> These modes have the same vibrational characteristics on all violins, regardless of their price.<sup>16</sup>

### **Contemporary Violinmakers Copying Cremona**

Violinmakers, Joseph Curtin and Gregg Aft, have been commissioned to make instruments by renowned violinists, such as Yehudi Menuhin, Ruggiero Ricci, and Elmar Oliveira. Their instruments are used by players in nearly two dozen major orchestras

---

<sup>13</sup> John S. Schelleng, "The Physics of the Bowed String," 69-77 in *The Physics of Music*, ed. by Carleen Hutchins (Scientific American, San Francisco: W. H. Freeman & Company, 1978), 75.

<sup>14</sup> Catgut Acoustical Society, <http://www.catgutacoustical.org/> (accessed August 10, 2008).

<sup>15</sup> Kenneth D. Marshall, "Modal Analysis of a Violin," *Acoustical Society of America* 77 (February 1985): 697.

<sup>16</sup> Marshall, 697.

around the world.<sup>17</sup> Curtin and Aft worked closely with Carleen Hutchins, Professor Gabriel Weinreich and others, and still use Hutchins' set-up for assessing and altering the vibrational modes using Chladni's patterns. Their research has begun to narrow the differences between the Old Italian violins and contemporary violins. Curtin claims that his research into making replicas is a way of studying how the great violin masters made their instruments, he also does this "as an accommodation to the players who are in transition from a time when it was practical to perform on golden period Cremonese instruments."<sup>18</sup> Their ability to measure and replicate the acoustical properties of a Cremona violin has far-reaching implications for the professional violinist, primarily financial. More violinists are able to purchase a high-quality acoustical new instrument, which has the playability properties of the prohibitory expensive Cremona instruments by Stradivari and his contemporaries.

### **Celebrated Scientists**

In the next section, the early breakthroughs in the physics of sound will be discussed. Scientists Chladni, Helmholtz, and Schelleng will help provide an uncomplicated, lucid visualization of vibration, which is the fundament element of tone-production.

---

<sup>17</sup> Stewart Pollens, "Curtains for Cremona," *The Strad* 106, no. 1267 (November 1995): 1160.

<sup>18</sup> Pollens, 1160.

## **Ernst Florens Friedrich Chladni**

Ernst Chladni's work on the vibration of plates has served as the foundation of many experiments by other scientists. His study consists of vibrating a fixed, circular plate with a violin bow and then sprinkling fine sand across it to show the various modal lines and patterns. Chladni demonstrated his findings in royal academies and scientific institutions, and frequently drew large crowds who were aptly impressed with the aesthetically sophisticated qualities of vibrating plates. Napoleon himself was so pleased with Chladni's work that he commissioned further study of the mathematical principles of vibrating plates, which then spurred a plethora of research in waves and acoustics. While experimental methods and equipment have been much improved in the last 200 years, Chladni's law and original patterns are still regularly employed to study plate vibrations.<sup>19</sup> These patterns are repetitive and distinct, serving as visual representation of sound waves.<sup>20</sup>

---

<sup>19</sup> Thomas D. Rossing, "Chladni's Law for Vibrating Plates," *American Journal of Physics* 50, no. 3 (March 1982): 271.

<sup>20</sup> Johannes Courtial and Kevin O'Holleran, "Experiments with Twisted Light: Some of the Mechanical and Quantum-Mechanical Properties of Optical Vortices," *European Physical Journal - Special Topics* (June 2007): 36, <http://www.physics.gla.ac.uk/Optics/papers/authorPDFs/Courtial-OHolleran-2007.pdf>. (accessed November 28, 2008).

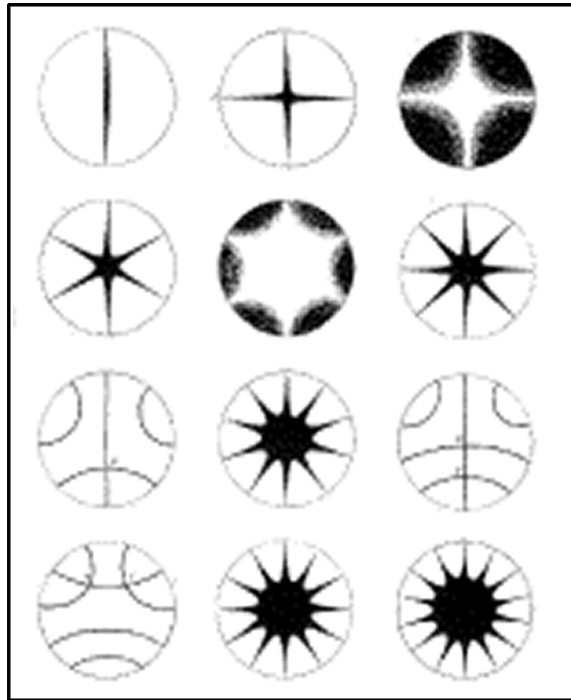

**Figure 4.01: Ernest Chladni's Vibrational Modes** (Reprinted with permission from David Pratt, "Patterns in Nature Part II: Chladni Plates," *Our World on CompuServe* (January 2006). <http://ourworld.compuserve.com/homepages/DP5/pattern2.htm#p1> .)

The first five vibrational modes on the violin, called Signature Modes, correspond with the first position range on the violin. Kenneth Marshall characterized five low-lying normal modes that contribute to the overall response in the first position string region of the violin; a nominally between 196 to 600 Hz.<sup>21</sup> He states, "these [five low-lying

---

<sup>21</sup> Marshall, 696.

normal modes] have been seen for all violins tested to date, regardless of quality.”<sup>22</sup>

Therefore, within the first position register on the violin, it should not make a difference whether a student is playing on an inexpensive violin or a high priced Cremona violin, the vibration qualities in the wood are exactly the same.

Research on Signature Modes continues with physicist George Bissinger, at East Carolina University. His studies on the modal qualities of the violin show that “all violins tested showed the same five Signature Modes below 600 Hz.”<sup>23</sup> According to Bissinger, “the ‘robust’ quality differentiator difference; was the approximately 280 Hz, Helmholtz-type A0 cavity mode.”<sup>24</sup> Therefore, if all violins contain these same five modes within the first position string range, then no matter what their value, when the string is engaged in Helmholtz Motion, the instrument has the capability of reaching its maximum tone quality.

Similar studies on Signature Modes are being carried out in the School of Physics at the University of New Southern Wales in Australia. Visiting researches, Emmanuel Bossy and Renaud Carpentier, give a side-by-side comparison of Chladni's first seven

---

<sup>22</sup> George Bissinger and David Oliver, “3.D Laser Vibrometry on Legendary Old Italian Violins,” (ProQuest Information and Learning Company, Violin Acoustics Laboratory at East Carolina University: *Acoustical Publications*, 2007), <http://www.acoustics.org/press/153rd/bissinger.html> (accessed February 9, 2009).

<sup>23</sup> George Bissinger, “Structural Acoustics of Good and Bad Violins,” *The Journal of the Acoustical Society of America* 124 (September 2008): 1754.

<sup>24</sup> Bissinger, “Structural Acoustics,” 1764.

vibrational modes using a hand-made German violin,<sup>25</sup> and an inexpensive, mass produced, Chinese violin.<sup>26</sup>

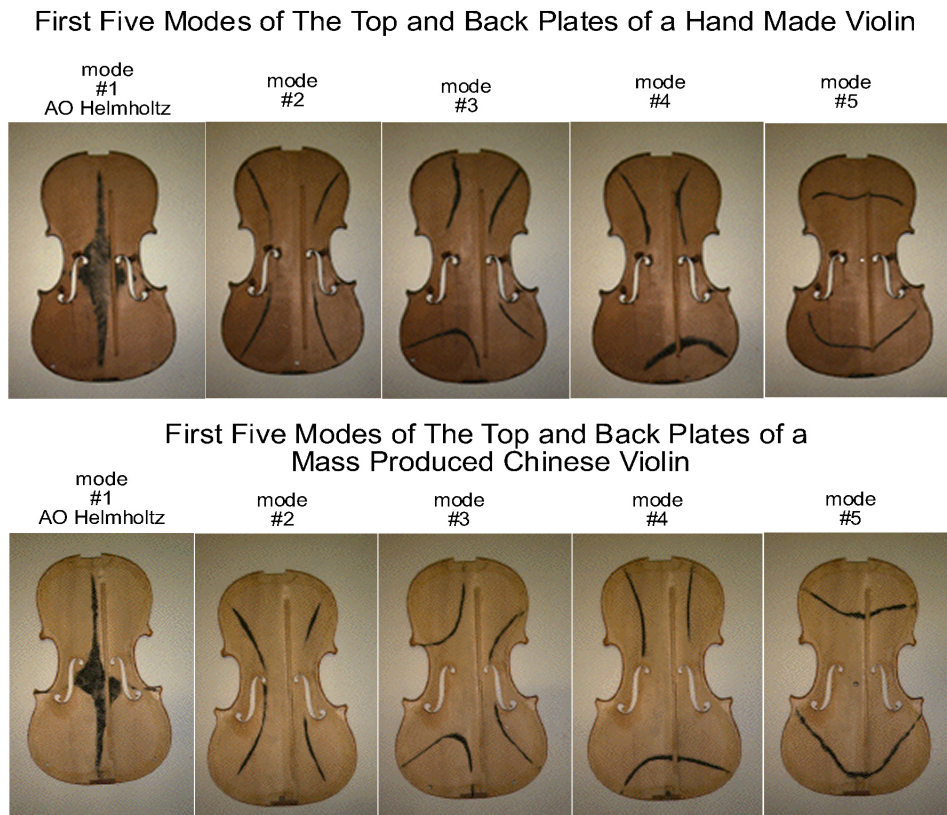

**Figure 4.02 First Five Signature Modes are the Same on All Violins** (Reprinted with permission from Emmanuel Bossy, and Renaud Carpentier, (Physics Department, University of Southern Wales, Australia), cropped, <http://www.phys.unsw.edu.au/jw/patterns1.html> and <http://www.phys.unsw.edu.au/jw/patterns2.html>.) Copyright 2006, University of South Wales.)

---

<sup>25</sup> Emmanuel Bossy and Renaud Carpentier, *First Seven Modes of the Top and Back Plates of a Hand Made Violin*, (Physics Department, University of Southern Wales Australia), <http://www.phys.unsw.edu.au/jw/patterns1.html> (accessed February 15, 2009).

<sup>26</sup> Bossy, <http://www.phys.unsw.edu.au/jw/patterns1.html>.

Because the amplitudes (size) of the harmonics determine the quality of tone produced, it is important to know that the Signature Modes are the same on all violins, therefore, allowing all violins the same opportunity to produce the Helmholtz Motion.

Modal tuning is a process practiced by violinmakers, specifically tuning of the Signature Modes. In figure 4.03, Hutchins and Voskuil have a chart describing each Signature Mode on the violin. This chart can be used in the violinmaker workshop for tuning the instrument's plates. Violas and cellos are similar, but tune to a lower frequency.

<b>Signature Modes:</b>	<b>Mode Definition:</b>
A0 260-290 Hz	“Helmholtz,” the so-called breathing mode.
B0 250- 300 Hz	First bending of neck and slight bending of body. Nodes across lower bout, at body/neck joint and at nut. A non-radiating mode.
A1 430-490 Hz	Internal, end-to-end cavity mode (longitudinal standing wave) with one node across C-bout area.
B1 480-590 Hz	First prominent top plate mode of assembled instrument with some bending of ribs and back. Top is most active, especially at bridge and bass bar area.
B-1 145-190 Hz	A rigid motion of body and neck rocking around the node across C-bout (like a see-saw) with a hinge joint at nut. A non-radiating mode.

**Figure 4.03: Mode Tuning For the Violinmaker** (Reprinted with permission from Carleen M. Hutchins and Duane Voskuil, *Catgut Acoustical Society Journal* 2, no. 4, Series II (November 1993): 8 cropped, <http://www.catgutacoustical.org/research/articles/modetune/> (accessed February 15, 2009). Copyright 1993, Catgut Acoustical Society.)

Consequently, when violins are bowed in first-position on the G, D A, and E strings, the largest-size harmonic upper partials are created and a quality of sound is produced on the instrument. This is not to suggest that all instruments are equivalent, but the core element of tone quality is accessible to all.

### **Hermann von Helmholtz**

Hermann von Helmholtz, a German physicist in the nineteenth-century, discovered that when a string is fully vibrating it has a “corner” that travels, between the bridge and the nut. The corner is sometimes referred to as a “kink,” because of its shape.<sup>27</sup> A Helmholtz corner is produced when a bow is pulled across the string with enough pressure for the horsehairs to catch, and is the essential and the most fundamental bow technique that needs to occur to achieve a good quality tone, and whereupon all dynamic variations are built.<sup>28</sup>

Helmholtz published his masterpiece, *On the Sensation of Tone as a Physiological Basis for the Theory of Music* in 1863. He showed that tone quality depends on the number and intensity of the partials or harmonics that may, and usually do, enter into the structure of a musical tone.<sup>29</sup>

---

<sup>27</sup> Helmholtz, 83.

<sup>28</sup> Helmholtz, 83.

<sup>29</sup> Eric Jansson, “Chapter VII: The Tone and Tonal Quality of the Violin,” in *Acoustics for Violin and Guitar Maker*, 4<sup>th</sup> ed. (KTH Royal Institute of Technology, 2002), <http://www.speech.kth.se/music/acviguit4/index.html> (accessed August 10, 2008).

As Professor of Physics at the University of Berlin, Helmholtz studied the motion that a string makes when it vibrates. The motion that is seen by the naked eye is quite different than the motion the vibrating string actually makes. In honor of his discovery, the University of Berlin named this corner, Helmholtz Motion.

During the nineteenth-century, Helmholtz did not have the possibility of using an oscilloscope to observe string vibration; instead, he made a kind of mechanical stroboscope. He used a string, which was blackened except for a white dot, and he observed it in a dark room through a stroboscope (primitive oscilloscope) attached to a vibrating tuning fork.<sup>30</sup>

When a violin bow is drawn across a string, the string appears to swing back and forth. However, Helmholtz revealed that this envelope of motion is actually described as a “corner” that divides the string into two straight halves and moves in a repeating cycle traveling from the bridge to the nut and returning. When this “corner” is in the part of its journey between the bow and the nut, the string moves with the bow and is said to be “sticking” to the bow. When the “corner” is between the bow and the bridge, the string slips rapidly in the direction opposite that of the bow movement and is said to be “slipping.”<sup>31</sup>

---

<sup>30</sup> John Woodhouse and Paul Galluzzo, “Why Is the Violin So Hard to Play?” *Plus Magazine* 31, no. 9 (September 2004), <http://plus.maths.org/issue31/features/woodhouse/index.html#observe> (accessed August 26, 2008).

<sup>31</sup> Diane Young, “New Frontiers of Expression through Real-Time Dynamics Measurement of Violin Bows,” (PhD diss., Massachusetts Institute of Technology, 2001), 12.

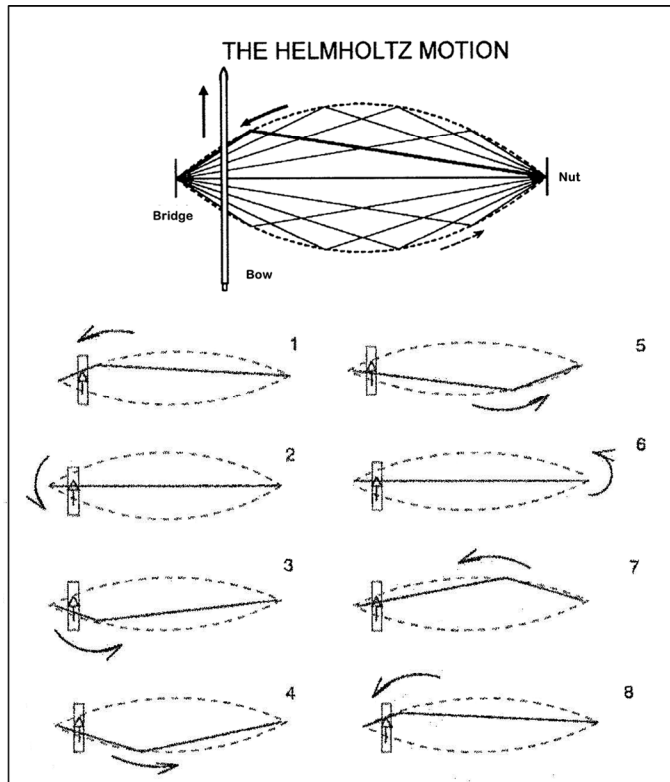

**Figure 4.04: The Helmholtz Motion** (Reprinted with permission from Stefania Serafin, “The Sound of Friction: Real-Time Models, Playability, and Musical Applications,” (PhD diss., Stanford University, 2004), 21. Copyright 2004, Stefania Serafin.)

Each time the corner reflects back from the bridge and passes underneath the bow, the bow has to replace the lost energy. It has to exert a short impulse on the string so that it moves again at the same velocity as the bow.<sup>32</sup> Stefania Serafin’s diagram, (figure 4.04), shows each cycle of the Helmholtz corner as it travels to make a complete circuit.

---

<sup>32</sup> Colin Gough, “Science and the Stradivarius,” *Acoustal Society of America* (April 1, 2000), <http://physicsworld.com/> (accessed August 10, 2008).

Figure 4.05 is a diagram of a string engaged in Helmholtz Motion, showing the path the corner travels as it completes a full circuit to produce a tone. Producing one Helmholtz corner per cycle is the critical aspect of behavior in a vibrating string, and is needed to produce the highest quality of tone from the instrument. One cycle is when the corner travels on the edge of the string from the bridge to the nut, and returns back to the bridge.

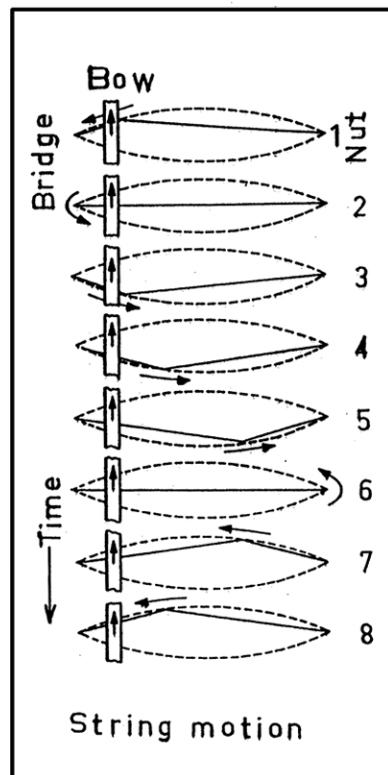

**Figure 4.05: Bowed String Motion** (Reprinted with permission from John McLennan, “The Art, History and Science of Violin Making” (lecture, University of Newcastle: Australia, August 1993), 4, cropped. Copyright 1993, University of Newcastle.)

The Helmholtz corner will travel different velocities to complete the full circuit, based on the pitch of the note. For example, if A440 is played, then the corner travels

this circuit 440 times per second.<sup>33</sup> The behavior of the string when it is bowed, is referred to as stick and slip motion.<sup>34</sup> The bow pulls the string to one side until the resisting force in the string disengages it. The corner produced moves first toward the bridge, then back to the bow as the string slips under the hair. When the corner reaches the bow, the string is picked up by the hair and carried with it, but the corner travels past the bow to the nut and back to its starting point ready to slip again. Creating and maintaining a single Helmholtz corner per cycle is vital for the tone to contain a mixture of higher harmonics.<sup>35</sup>

During Helmholtz Motion, the string sticks and slips along the bow one time, making a complete cycle. This motion of sticking and slipping while the bow is being pulled across a string cannot be seen by the naked eye. What can be seen is the outer envelope of the motion.<sup>36</sup> Jim Woodhouse and Paul Galluzzo, professors at Cambridge University, provide a visual aid of what the string looks like to the naked eye in figure 4.06:

---

<sup>33</sup> John McLennan, "The Art, History and Science of Violin Making," (lecture, Department of Mechanical Engineering, University of Newcastle: Australia, August 1993), 4, <http://www.phys.unsw.edu.au/music/publications/mclennan/arthistoryscience.pdf> (accessed January 24, 2009).

<sup>34</sup> Helmholtz, 83.

<sup>35</sup> Helmholtz, 83.

<sup>36</sup> Woodhouse, "Why Violin Hard Play?"

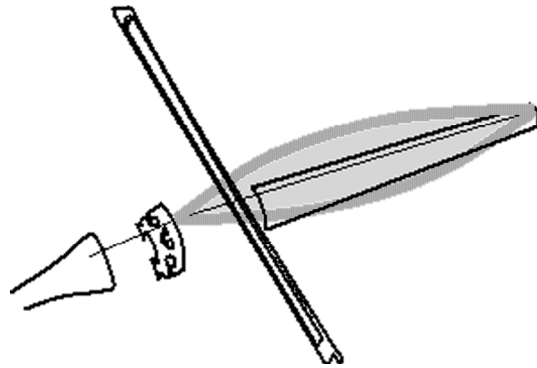
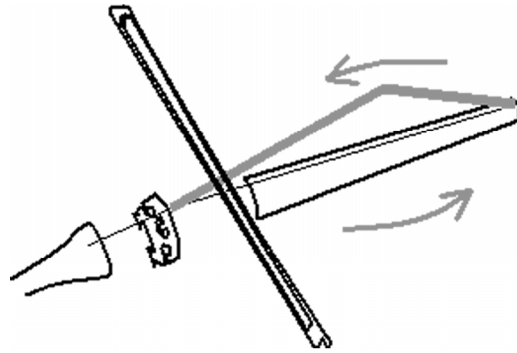

**Figure 4.06: What the Player Sees** (Reprinted with permission from Jim Woodhouse and Paul Galluzzo, “Why Is the Violin So Hard to Play?” +*Plus Magazine* 31, no. 9 (September 2004), <http://plus.maths.org/issue31/features/woodhouse/index.htm>.)

The drawing in figure 4.07 illustrates the “corner” in the vibration, which forms the two motions for the string to vibrate. This is the Helmholtz Motion. Only one Helmholtz Motion in a vibration cycle will produce enough harmonic upper partials to create the best quality of sound.<sup>37</sup> This motion is what professional string players try to achieve the first moment the bow touches a string. Helmholtz Motion is achieved by pressure on the bow resulting in an abundance of the harmonics, sounding solid, intense, and concentrated sound.

---

<sup>37</sup> Woodhouse, “Why Violin Hard Play?”.



**Figure 4.07: The “kink” called Helmholtz Motion** (Reprinted with permission from Jim Woodhouse and Paul Galluzzo, “Why Is the Violin So Hard to Play?” *Plus Magazine* 31, no. 9 (September 2004), <http://plus.maths.org/issue31/features/woodhouse/index.htm>.)

Helmholtz observed one other very different motion of the string called “double-kink,” or double-slipping motion, seen below in figure 4.08.”<sup>38</sup>

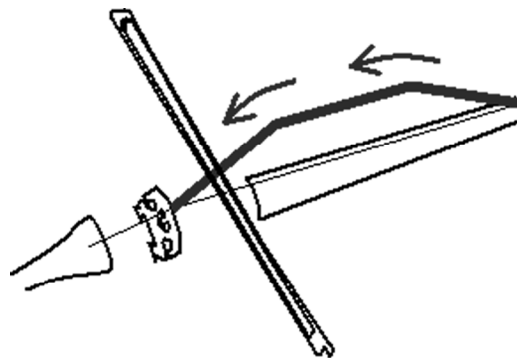

**Figure 4.08: Double Kink in the Helmholtz Motion** (Reprinted with permission from Jim Woodhouse and Paul Galluzzo, “Why Is the Violin So Hard to Play?” *Plus Magazine* 31, no. 9 (September 2004), <http://plus.maths.org/issue31/features/woodhouse/index.htm>.)

---

<sup>38</sup> Woodhouse, “Why Violin Hard Play?”.

The double-kink motion will occur when there is too little pressure on the bow as it is pulled across the string, producing weak upper harmonic partials. This will sound whistling, thin, and unfocused. This motion happens when the bow does not catch the string, creating two (sometimes more) Helmholtz corners within one cycle. In figure 4.09, the top of the graph demonstrates the string vibration in Helmholtz Motion. This will create a “squeak” or “raucousness” tone at the starting note. The bottom part of the graph demonstrates the double-kink in the string vibration. This will create a “slipping” or “surface noise.”<sup>39</sup>

---

<sup>39</sup> Linda Day, “Analyzing the Tribology of Sound,” *Tribology & Lubrication Technology* 1 (January 2007): 28-39, [http://www2.eng.cam.ac.uk/~jw12/JW%20PDFs/feature\\_1-07.pdf](http://www2.eng.cam.ac.uk/~jw12/JW%20PDFs/feature_1-07.pdf) (accessed November 25, 2008).

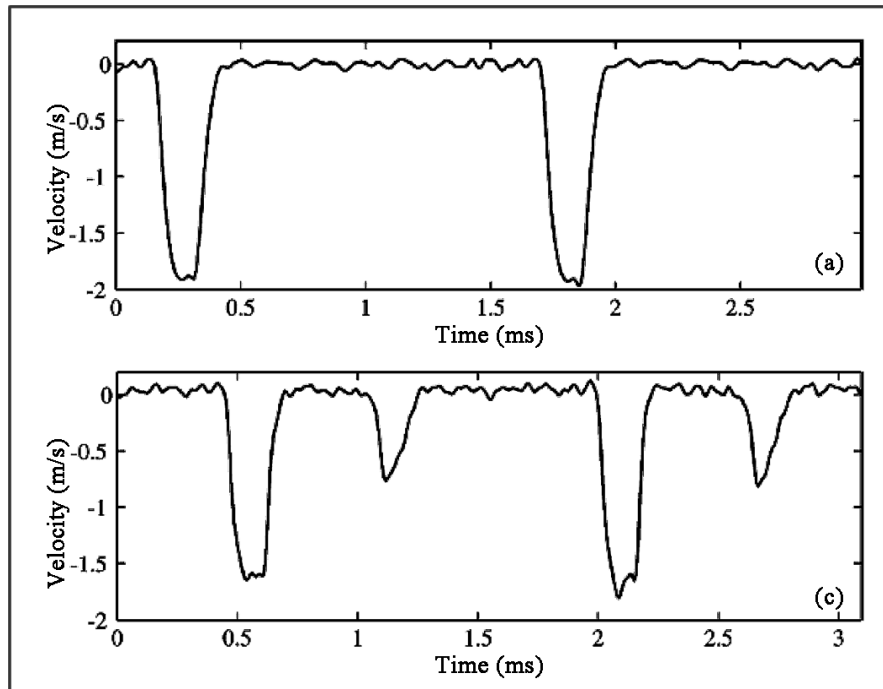

**Figure 4.09: Helmholtz Motion and Double-Slip** (Reprinted with permission from Linda Day, “Helmholtz Motion (top) and ‘surface sound’ (bottom),” “in Analyzing the Tribology of Sound,” *Tribology & Lubrication Technology* (January 2007): 37. Copyright 2007, Tribology & Lubrication Technology.)

Helmholtz describes a musical tone as compound, meaning it is made up of a series of different pitches.<sup>40</sup> “The first and closest pitch is the prime partial tone of the compound and the rest its harmonic upper partial tones.”<sup>41</sup> Helmholtz determined that the quality of tone depends on the form of vibration (Helmholtz Motion), and the strength and number of the harmonic upper partial tones. Helmholtz described the general characteristic of a perfectly formed string vibration (Helmholtz Motion) as having a “metallic quality of

---

<sup>40</sup> Helmholtz, 23.

<sup>41</sup> Helmholtz, 23.

tone,” and it was this particular characteristic in a tone that maintained and sustained the higher upper partials.<sup>42</sup> When the form of vibration (Helmholtz Motion) does not contain a rich amount of harmonic upper partials, then the tone will be diminished in amplitude and quality.<sup>43</sup>

During Helmholtz’s time, the overtone series<sup>44</sup> was looked at as a kind of “strange and unexpected phenomenon,” and was “regarded as a mere curiosity,” insignificant to musical tone.<sup>45</sup> Helmholtz discovered, “there is a whole series of higher musical tones, which he called the harmonic upper partial tones[,] . . . and they are in contradistinction to the fundamental or prime partial tone[,] . . . which is the lowest and generally the loudest of all the partial tones, and by the pitch of which we judge of the pitch of the whole compound musical tone itself.”<sup>46</sup> Helmholtz determined that this series is not only “precisely the same for all compound music notes,” it is necessary for producing good quality in a vibrating string.<sup>47</sup>

---

<sup>42</sup> Helmholtz, 71.

<sup>43</sup> Helmholtz, 71.

<sup>44</sup> “Harmonic upper partials” was translated from German to English as “overtone series.” Helmholtz was quite unhappy with this translation. This author tried to be consistent and use the term, “harmonic upper partials” whenever possible.

<sup>45</sup> Helmholtz, 22.

<sup>46</sup> Helmholtz, 22.

<sup>47</sup> Helmholtz, 22.

The second and third partial notes in the vibration series (overtone series) is described by Helmholtz:

1. The first upper partial tone [or second harmonic] is the upper Octave of the prime tone, and makes double the number of vibrations in the same time.
2. The second upper partial tone [or third harmonic] is the Fifth of this Octave, making three times as many vibrations in the same time as the prime.<sup>48</sup>

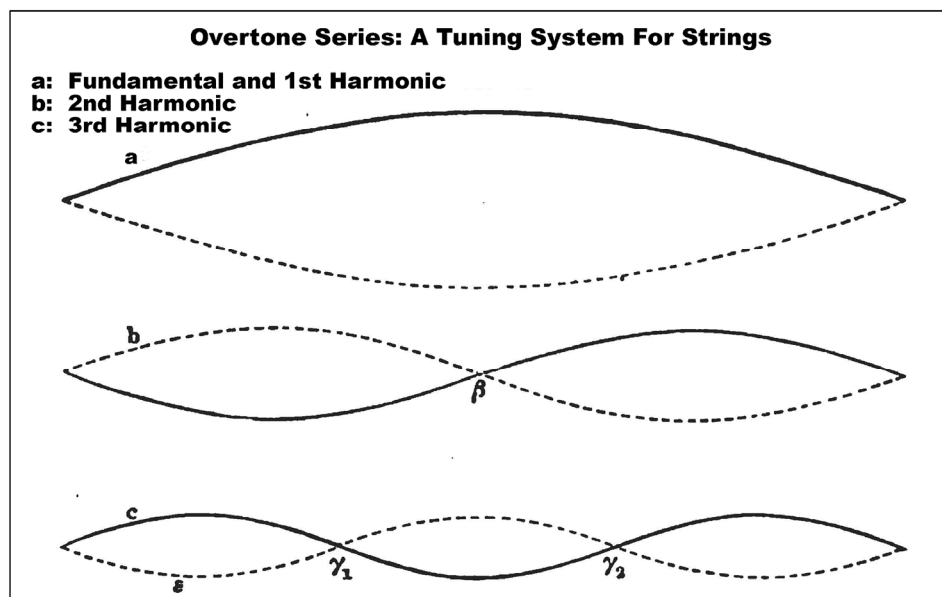

**Figure 4.10: Sympathetic Resonance of Strings-The Form of Vibration** (Hermann von Helmholtz, *On the Sensation of Tone as a Physiological Basis for the Theory of Music*, tran. Alexander John Ellis, 4<sup>th</sup> ed. (New York: Longmans, Green, Doves, 1912), 46, cropped.)

---

<sup>48</sup> Helmholtz, 22.

Knut Guettler, professor at the Royal Institute of Technology, experimented with the listener's ability to tolerate the initial 'attack noise' that is created when the player produces the Helmholtz Motion on the string. Guettler found that the listener's tolerance was based in their judgment of the character of the noise, and that "slipping noise" was better tolerated than "creaks" or "raucousness" at the beginning of the tone.<sup>49</sup>

The other important aspect of sound was discovered by John S. Schelleng.<sup>50</sup> In 1973, Schelleng established a diagram, named the "Schelleng Diagram," representing the region where a Helmholtz Motion can be maintained in function of the bow-bridge distance and to the downward force on the string. In addition, Schelleng identified other regions where the bowed string waveform shows spectral properties and therefore associated perceptual adjectives such as "raucous" or "higher modes."<sup>51</sup> When Helmholtz Motion and the Schelleng Diagram are used together, they illustrate the basic characteristics of good tone-production on the violin.

### **John C. Schelleng**

Professor John C. Schelleng formalized the maximum and minimum bow force for production of Helmholtz Motion. The Schelleng Diagram is the scientific model to

---

<sup>49</sup> Knut Guettler, "The Bowed String: On the Development of Helmholtz Motion: On the Creation of Anomalous Low Frequencies," (PhD diss., Royal Institute of Technology, 2002).

<sup>50</sup> Schelleng, "The Physics," 75.

<sup>51</sup> Nicolas Hainiandry Rasamimanana, "Gesture Analysis of Bow Strokes Using an Augmented Violin," (PhD diss., University Pierre and Marie Curie: Paris, 2004), 32.

show how the position of the bow and how the motion of the string relates to good tone-production. The Schelleng Diagram is said to display at a glance the region of good behavior for the bowed string model, i.e., the region of the parameter space in which simple Helmholtz Motion is obtained when the speed of the bow remains constant.

In figure 4.11, the left of the graph shows minimum and maximum bow force. The bottom shows the bow's distance from the bridge. Between the two parallel lines are the bow-force limits. The combinations of these two parameters allow Helmholtz Motion to occur, creating the largest possible amplitudes in the vibrating upper partial harmonics, thus producing the best quality of tone.<sup>52</sup>

---

<sup>52</sup> Schelleng, "The Physics," 75.

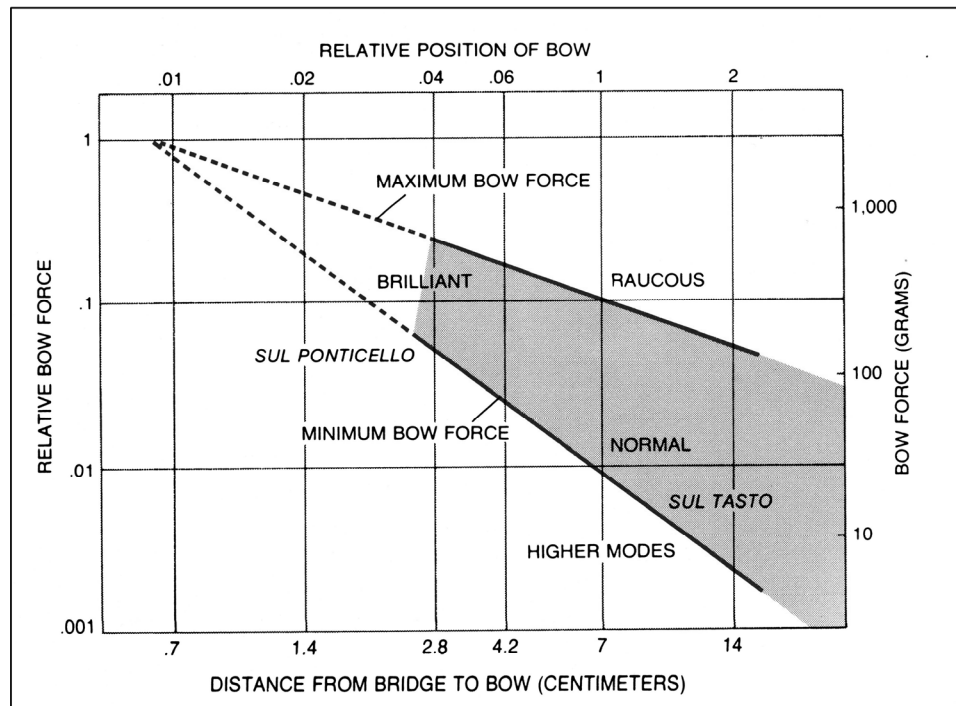
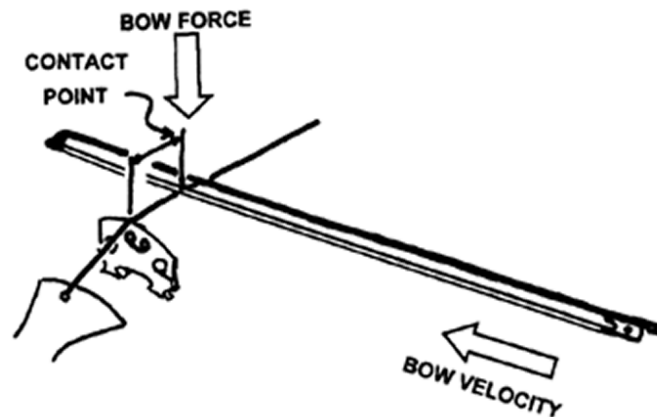

**Figure 4.11: The Schelleng Diagram** (Reprinted with permission from John C. Schelleng, “The Physics of the Bowed String,” 70-77 in *The Physics of Music*, ed. by Carleen Hutchins, Scientific American (San Francisco: W. H. Freeman & Company, 1978), 75. Copyright 1978, Scientific American.)

### Anders Askenfelt and Erik Jansson

Anders Askenfelt, professor at the Royal Institute of Technology (KTH) in the Department of Speech, Music, and Hearing in Stockholm, Sweden, and Erik Jansson, a distinguished professor and researcher in music acoustics, work together to forge a path for understanding the science of violin tone-production. Askenfelt published a paper in 1988 titled, “Measurement of the Bowing Parameters in Violin Playing. II: Bow-bridge Distance, Dynamic Range, and Limits of Bow Force,” in the *Journal of the Acoustical Society of America*. As the leading scientist in the field of acoustics, Askenfelt states, “a

violin player selects the bowing parameters with high accuracy, consciously and unconsciously” is using his or her ears.<sup>53</sup> Therefore, a violinist has to select the contact point “bow-string bow position,” the force the bow is pressed against the string “bow pressure,” and the bow velocity to select the “right” tone.<sup>54</sup> The combinations of these factors need to be continuously changed for the “right” resulting tone quality. Askenfelt notes that the bow-bridge distance, the amount of bow pressure and the bow’s velocity, are not notated in a music score, therefore it is left up to the player to determine the placement, pressure and velocity of the bow with respect to what the composer wants musically.<sup>55</sup>



**Figure 4.12: Measurement of the Bowing Parameters** (Reprinted with permission from Anders Askenfelt, “Measurement of the Bowing Parameters in Violin Playing,” *Journal of the Acoustical Society of America* 84 (November 1988): 163, <http://www.speech.kth.se/qpsr>. Copyright 1988, Acoustical Society of America.)

---

<sup>53</sup> Askenfelt, “Bowing Parameters,” 163.

<sup>54</sup> Askenfelt, “Bowing Parameters,” 163.

<sup>55</sup> Askenfelt, “Bowing Parameters,” 163.

In 2007, Erwin Schoonderwaldt, Knut Guettler, and Anders Askenfelt, from the Royal Institute of Technology challenged Schelleng's outer bow force limits in its ability to maintain the Helmholtz Motion. It was determined that, "the maximum bow force limit for Helmholtz Motion corresponded well to Schelleng's equation . . ." <sup>56</sup> They also re-emphasized in the study, ". . . minimum and maximum bow-force limits should be proportional with bow velocity." <sup>57</sup>

### **Chandrasekhara Venkata Raman**

The research discussed previously in the chapter is based on amplifying the vibration of the violin string. There is also research using designed controllers that sense the bowing gestures that produce the dynamic and timbral expression of the violin. One of the first to experiment with this idea was Chandrasekhara Venkata Raman. In 1920, Raman wrote an article in the Indian Academy of Sciences, entitled *Experiments with Mechanically-Played Violins*. <sup>58</sup> In this article, Raman details the design of a "mechanical player" that permitted "accurate measurements of the pressure and speed of bowing" and

---

<sup>56</sup> Erwin Schoonderwaldt, Knut Guettler, and Anders Askenfelt, "Schelling in Retrospect - a Systematic Study of Bow Force Limits for Bowed Violin Strings," (lecture, International Symposium on Musical Acoustics, Barcelona, 2007), 5, <http://www.speech.kth.se/> (accessed November 30, 2008).

<sup>57</sup> Schoonderwaldt, 5.

<sup>58</sup> Chandrasekhara Venkata Raman, "Experiments with Mechanically-Played Violins." *Proceedings of the Indian Association for the Cultivation of Science*. Bangalore: Indian Academy of Sciences 6 (1920): 19-36. <http://hdl.handle.net/2289/2167>. (accessed November 23, 2008).

allows for “the discrimination by ear of the effect of varying these factors.”<sup>59</sup> This invention uses an ordinary violin and bow, mounted to an apparatus that moves the violin back and forth, under the bow, with an electric motor. Raman experiments with the interactions between variations of bow speed, pressure, and position, under controlled conditions.

Subsequent researchers continue to certify the importance of bow speed, pressure and position as a condition of playing, and its effects on tone quality. Important in this research is the work of Askenfelt.

Askenfelt’s description of the interaction between bow force and position is, “the minimum bow force required to maintain the string oscillations increases as the bow is moved closer to the bridge.”<sup>60</sup> The player observes this relationship by normally increasing the bow force while decreasing the bow-bridge distance. In figure 4.13, Askenfelt outlines the following four bowing parameters that a string player has access to, which can be used in various combinations enabling the player to produce a wide range of dynamics and sound qualities.

- 1) **Bow position:** The transverse position of the bow in relationship to the frog or to the tip, and was measured by embedded a piece of resistive wire in the bow

---

<sup>59</sup> Raman, “Mechanically-Played Violins,” 409.

<sup>60</sup> Askenfelt, “Bowling Parameters II: Bow-Bridge Distance, Dynamic Range, and Limits of Bow Force,” *Journal of the Acoustical Society of America* 86, no. 8 (1989): 505.

hair while the violin strings were connected to the ground of an external Wheatstone bridge. The bridge was adjusted to balance when the middle part of the bow was in contact with the string. Therefore, other bow positions gave positive or negative signals accordingly.

- 2) **Bow velocity:** The velocity of the bow transverse to the strings. Bow velocity was obtained by differentiating the bow position signals with respect to time.
- 3) **Bow force:** The force between bow and string, normal to the direction of the bow and string. Bow pressure was obtained by mounting sensors for bow force, comprising four strain gauges, on bronze strips through which the bow hairs were fastened to the bow. These gauges were connected to a second Wheatstone bridge.
- 4) **Bow-bridge distance:** The bow-bridge distance was measured in a third Wheatstone bridge using the same detection principle as for the bow position. The string itself was now used as a resistance wire. The bow wire divided the string into two “resisters,” with the resistance ratio determined by the momentary contact point with the bow.<sup>61</sup>

---

<sup>61</sup> Askenfelt, “Bowling Parameters II,” 505.

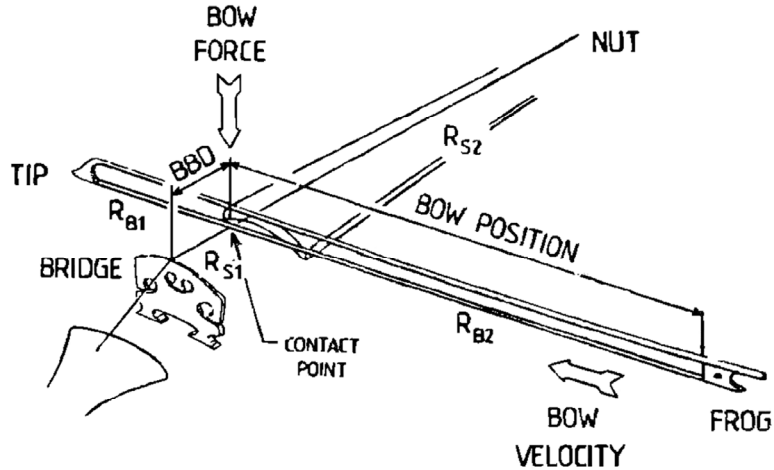

**Figure 4.13: Interactions between Bow Force, Contact Point, Bow Velocity, and Bow Position** (Reprinted with permission from Anders Askenfelt, “Measurement of the Bowing Parameters in Violin Playing II: Bow-Bridge Distance, Dynamic Range, and Limits of Bow Force,” *Journal of the Acoustical Society of America* 86, no 2 (February 1989): 505, <http://www.speech.kth.se/qpsr>. Copyright 1989, Acoustical Society of America.)

Askenfelt experiments with measuring the dynamic range that can be reached using these four parameters. He concludes that bow speed has the greatest impact in dynamic changes when the length of the note was short and the change in dynamic needed to be sudden. When the length of the note was long and the dynamic change was gradual, then bow-bridge distance was the most effective. In his report Askenfelt states, “the bow-bridge distance seems to be the most versatile bowing parameter.”<sup>62</sup>

The results of Askenfelt’s study of each of the three bow parameters are shown in figure 4.14. The ends of the thick bars represent extreme values, while ranges typically

---

<sup>62</sup> Askenfelt, “Bowing Parameters II,” 513.

used by violinists used are shaded. The small boxes marked with a triangle indicate the players' ability to control the bow-bridge distance and bow force during long bow strokes.<sup>63</sup>

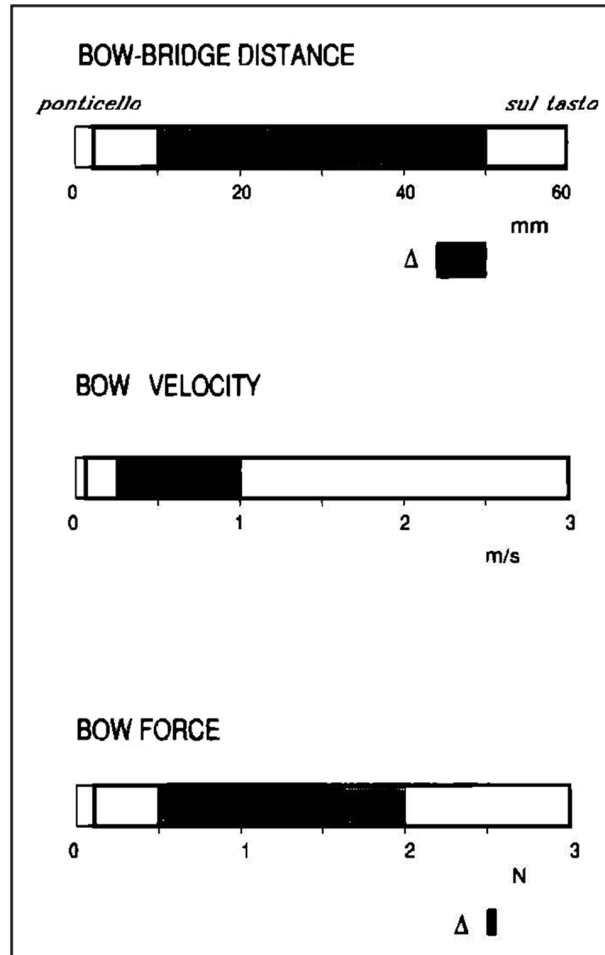

**Figure 4.14: Ranges of Variation for the Bowing Parameters** ((Reprinted with permission from Anders Askenfelt, “Measurement of the Bowing Parameters in Violin Playing II: Bow-Bridge Distance, Dynamic Range, and Limits of Bow Force,” *Journal of the Acoustical Society of America* 86, no 2 (February 1989):513, <http://www.speech.kth.se/qpsr>. Copyright 1989, Acoustical Society of America.)

<sup>63</sup> Askenfelt, “Bowing Parameters II,” 513.

Askenfelt's bowing parameters became the foundation for further research in measuring sound qualities.

### **New Research**

In the second half of the twentieth century, advanced technology provided the ability to build smaller measuring devices and more sophisticated computer programs to collect, compare, and share data, thus providing another means for understanding the importance of bow speed, bow pressure and bow placement. These new technologies provide researchers with new opportunities for in-depth investigation into the characteristics of sound.

### **Joseph Paradiso and Neil Gershenfeld**

Researchers at the MIT Media Laboratory, Joseph Paradiso and Neil Gershenfeld, developed a system for tracking bow position, laterally from frog to tip and longitudinally relative to the bridge, using electric field sensing.<sup>64</sup> Cellist, Yo-Yo Ma performed Tod Machover's composition, *Begin Again, Again . . .* on the Hypercello and Hypercello

---

<sup>64</sup> Joseph A. Paradiso and Neil Gershenfeld, "Musical Applications of Electric Field Sensing Physics," *Computer Science Journal* (1996): 12, [http://www.media.mit.edu/resenv/pubs/papers/96\\_04\\_cmj](http://www.media.mit.edu/resenv/pubs/papers/96_04_cmj), (accessed May 5, 2006).

Bow version of this system.<sup>65</sup> Figure 4.15 shows Yo-Yo Ma playing the system at the Tanglewood debut on August 14, 1991.



**Figure 4.15: Cellist Yo Yo Ma Performing in Concert on the Hypercello** (Reprinted with permission from Joseph A. Paradiso and Neil Gershenfeld, “Musical Applications of Electric Field Sensing Physics,” *Computer Science Journal* (April 1996): 12, [http://www.media.mit.edu/resenv/pubs/papers/96\\_04\\_cmj.pdf](http://www.media.mit.edu/resenv/pubs/papers/96_04_cmj.pdf).)

The hypercello bow uses a small antenna, which broadcast a sine wave from behind the bridge, to a “bow electrode,” comprised of a resistive strip affixed to a cello bow.<sup>66</sup> These bow sensors measure the bow pressure and placement between the bridge

---

<sup>65</sup> Paradiso, 12.

<sup>66</sup> Paradiso, 12.

and fingerboard unobtrusively, so the player's actions can be more accurately detected and notated. Refer to figure 4.16.

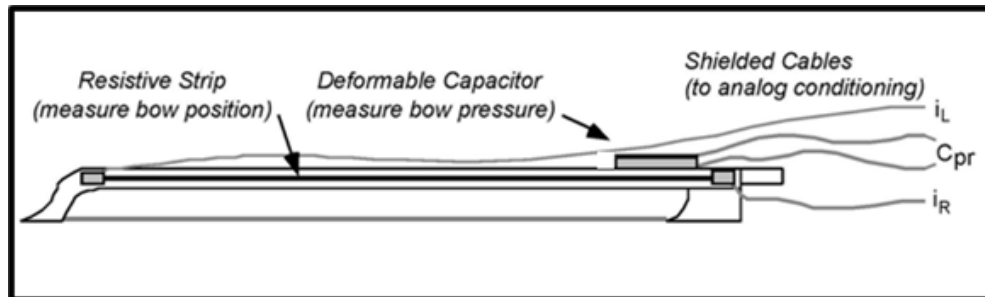

**Figure 4.16: Hypercello Bow** (Reprinted with permission from Joseph A. Paradiso and Neil Gershenfeld, "Musical Applications of Electric Field Sensing Physics," *Computer Science Journal* (April 1996): 12, [http://www.media.mit.edu/resenv/pubs/papers/96\\_04\\_cmj](http://www.media.mit.edu/resenv/pubs/papers/96_04_cmj).)

The results from these experiments parallel the tone-production pedagogies of the master teachers. Re-emphasizing that the player selects the combinations of bowing parameters, based on listening, however the three elements remain the same.

### Tracy Kwei-Liang Ho

Tracy Kwei-Liang Ho developed a computer assisted bowing machine in 1990, which can be used during home practice by students of all ages. Ho's bowing machine,

now patented, provides students with a visual tool for assessing tone-production.<sup>67</sup> The bowing machine combines all the parameters that need to be present for students to produce a good tone, and will compare their sound to that of their teachers.

Ho's essay connects the three parameters of sound production as specified in Galamian's treatise, *Principles of Violin Playing and Teaching*, then adds a rudimental element for measuring sound production with a computer visual tool. Ho applies scientific research artfully to the traditional bowing techniques for sound production. In this project, the computer and electronic technologies are used to assist students in developing skills on the violin.

The design includes four parameters that relate to the technique of sound production. They are:

- 1) Sounding point,
- 2) Bow pressure,
- 3) Bow velocity,
- 4) Bow position.

By adding the fourth parameter of bow position, which is where, along the length of bow, a violinist selects to start a note. Ho offers a greater number of assessable possibilities. The design of the system will generate a graphical display on a computer

---

<sup>67</sup> Tracy Ho, *Method and Apparatus for Teaching the Production of Tone in the Bowing of a Stringed Instrument*, (United States Patent #5038662, August 1991), <http://www.patentgenius.com/patent/5038662.html> (accessed January 29, 2009).

screen, as well as store data files for future use and analysis. Bow position is defined as where the bow initially touches the string. This additional parameter is measured by a “resistive wire” placed in the hair of the bow.<sup>68</sup> With the addition of bow position to the other three parameters discussed by Galamian, Flesh, Gerle, and Fischer, it minimizes the need for a teacher’s presence, and increases learning between the traditional weekly lessons. The addition of a visual aid is also helpful by engaging an alternative learning style to the traditional approach. Ho points out the naturalness of using a computer daily, and the ability for students to focus for long periods of time while using it.

The home practice machine has not found a place in the market thus far, which may mean that technology has its place within the strings classroom, but string teachers are not ready to embrace it fully. There may also be limited numbers of string teachers aware of these supplemental aids for teaching tone-production. Providing a practical approach easily accessible to teachers and conductors may provide this needed supplemental material.

### **Charles Nichols**

In 2003, Charles Nichols wrote his dissertation, *The vBow: an Expressive Musical Controller Haptic Human Computer Interface on the Role of Longitudinal String*

---

<sup>68</sup> Tracy Kwei-Liang Ho, “The Development of a Computer-Assisted Approach to the Teaching of Violin Tone Production,” (PhD diss., Columbia University Teachers College, 1990), 104.

*Vibrations*.<sup>69</sup> Nichols built the vBow, and designed it around the physical gestures of a violinist's bowing movement. Attached to the vBow is a "bow electrode" that generates Haptic feedback, corresponding to the bowing motion of the performer. "Haptics is the science and physiology of the sense of touch. There is a large section of the brain called the primary sensory cortex that is responsible for processing all the rich information flowing in from mechanoreceptors in your fingers, your face, and all over your body. These mechanoreceptors . . . allow you to feel things like touch, pressure, stretching, and motion."<sup>70</sup> Haptic feedback technology interfaces with the performer via the sense of touch, registering all vibrations and motions that are made.

As an instrument builder, Nichols, tried to "create a design and use equipment and materials that would maximize the expressive potential of the instrument (vBow)."<sup>71</sup> As a performer, Nichols wants an instrument that senses even the "smallest bowing gesture with acute resolution, affording me the greatest dynamic and timbral range possible."<sup>72</sup>

---

<sup>69</sup> Charles Sabin Nichols II, "The vBow: An Expressive Musical Controller Haptic Human-Computer Interface on the Role of Longitudinal String Vibrations," (PhD diss., Stanford University, 2003).

<sup>70</sup> Immersion Corporation, *What is Haptics* (San Jose, CA: Immersion Corporation, 2008), [http://www.immersion.com/corporate/press\\_room/what\\_is\\_haptics.php](http://www.immersion.com/corporate/press_room/what_is_haptics.php) (accessed January 28, 2009).

<sup>71</sup> Nichols, 74.

<sup>72</sup> Nichols, 33.

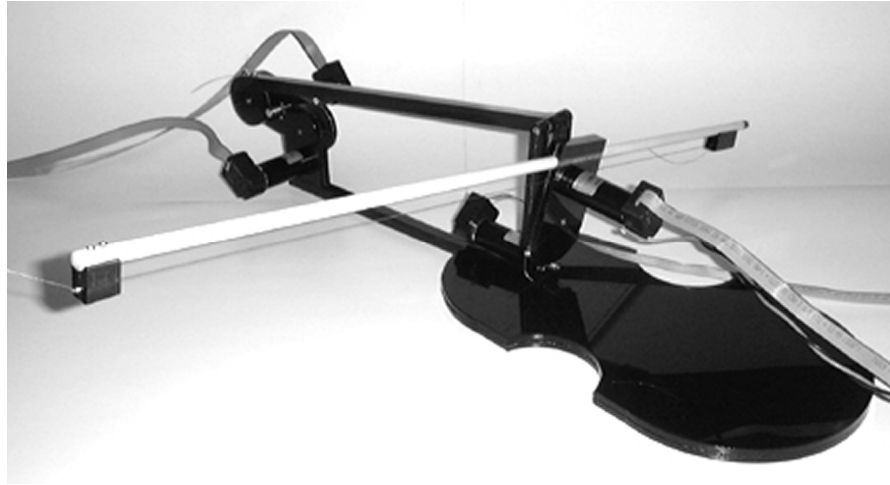

**Figure 4.17: The v-Bow, version 2** (Reprinted with permission from Charles Sabin Nichols II., “The vBow: An Expressive Musical Controller Haptic Human-Compute Interface on the Role of Longitudinal String Vibrations,” (PhD diss., Stanford University, 2003), 74. Copyright 2003, Charles Sabin Nichols II.)

The results of the data are conclusive: the speed and weight of the bow changes the brightness of the tone of the instrument. In addition, optimal bow velocity is needed to produce a clear tone on the instrument. If the bowing motion is too fast and too light of pressure, it produces a flautando tone: a tone that brings out only the highest upper harmonic partials, making the violin sound flute-like. Conversely, if the lateral motion of the vBow is too slow and the pressure too heavy, then a scratching sound is produced. Nichols’ vBow provides additional data which, “... further serves to demonstrate that it is the bow that provides the majority of the expressive variety in violin dynamics and texture.”<sup>73</sup>

---

<sup>73</sup> Nichols, v.

## **Diane Young**

While attending MIT, Diane Young developed and built a non-invasive system to measure the subtle, real-time changes in violin bowing gestures. Young's dissertation: *A Methodology for Investigation of Bowed String Performance through Measurement of Violin Bowing Technique*, published in 2007, focuses on calibration and playability, allowing for the least amount of disruption for the player.<sup>74</sup> The measurement system attaches to the bow, providing real-time assessment of the following bowing parameters: bow-bridge distance, bow force, and bow velocity. This system is small and wireless, and thereby optimal to capture the subtleties and nuances of the bow in performances of traditionally trained violinists.<sup>75</sup> Young uses the equations that govern Helmholtz Motion plus the bowing parameters of speed and bow-bridge distance. These are used to compute the maximum and minimum limits for bow force that would be expected to produce a good sound.

## **Alfonso Perez**

In 2007, a violin timbre model was developed by the Music Technology Group in Barcelona, Spain that takes into account performance gestures. The data and sound are

---

<sup>74</sup> Diane Young, "A Methodology for Investigation of Bowed String Performance through Measurement of Violin Bowing Technique," (PhD diss., Massachusetts Institute of Technology, 2007).

<sup>75</sup> Young, "Methodology for Investigation," 155.

synchronously captured by means of 3D trackers attached to the violin bridge.<sup>76</sup> The measuring system was developed to predict the outcome of combining different bowing parameters: (1) bow force (2) bow position between the bridge and the bridge (3) bow pressure (4) bow position, where the bow is placed between the frog and the tip on the string, and (5) what string is being played. The results indicate that *bow force* is the most significant variable.

The research investigated thus far in Chapter Four includes mechanical bows, bows with cables attached to computers played by professionals, and bows using Haptic technology, where the performer is unobstructed. The conclusion of this research is that no matter what the approach, there are three determining qualities for producing a good tone: bow pressure, bow speed and bow placement, all dependant on the string vibrating in the Helmholtz Motion.

### **Tone Quality**

Can good players make compensations to mask the inadequacies of a poor quality instrument? The esteemed conductor, composer, and pianist, André Previn, recalls a master class of Jascha Heifetz, when a student tried to blame her poor tone on an inferior

---

<sup>76</sup> Alfonso Perez, and others, “Combining Performance Actions with Spectral Models for Violin Sound Transformation,” conference paper, *19<sup>th</sup> International Congress on Acoustics*, Madrid: Music Technology Group (September 2007): 1-6, <http://mtg.upf.edu/files/publications/93f0a2-ICA-2007-perez.pdf>.

instrument, whereupon the master took it from her and demonstrated otherwise.<sup>77</sup> Most likely, Heifetz did not offer to buy her violin, but there is a way to explain how it was he was able to produce a good quality of tone on an inferior instrument.

### **George Bissinger**

Earlier in this chapter, there is a discussion on the vibrational properties with-in the body of the violin called Signature Modes. These modes produce the same vibrational results in every quality of instrument.<sup>78</sup> The height of the mode's frequencies, located on the left side of figure 4.18, is the measurement used in evaluating the different violins. The AO Helmholtz mode is the first and one of the strongest of the Signature Modes.

---

<sup>77</sup> André Previn, *No Minor Keys: My Days in Hollywood* (New York: Doubleday 1993), 33.

<sup>78</sup> Marshall, 697.

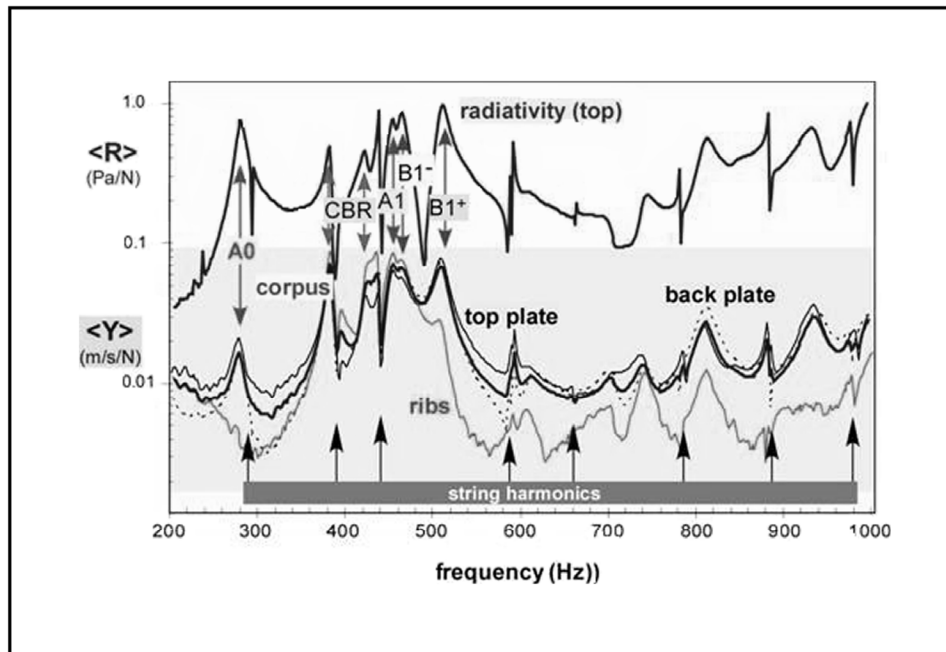

**Figure 4.18: Five Signature Modes in the Violin** (Reprinted with permission from George Bissinger and David Oliver, “3-D Laser Vibrometry on Legendary Old Italian Violins,” *Sound and Vibration* (July 2007):12, <http://www.sandv.com/downloads/0707biss.pdf>. Copyright 2007, Sound and Vibration.)

These five modes are the same on all violins, whether it is a hand made Cremona violin or a factory-made instrument. Therefore, Helmholtz Motion is possible on all violins in this range, and student violins can learn tone-production without the need to purchase an expensive instrument.

There seems to be a preconceived notion among many string teachers that the fastest way for a student to achieve a better tone is to purchase a better quality

instrument.<sup>79</sup> To some extent this is true, and when the student advances musically, the natural progression is for them to invest in a higher quality instrument. However, when teaching a class of beginners, most of who are playing on rental factory-made instruments, it is important to know that within the open string first position register the vibrational response of all violins is equivalent. Therefore, knowing that tone quality is “determined by the amplitudes [size] of the harmonics which are present,” the ability to produce the largest size of vibrating harmonics can be taught, regardless of the instrument’s quality.<sup>80</sup> It is important for students to learn how to engage the Helmholtz Motion, so that they can benefit from playing with the best possible tone quality their instrument can produce.

The next section includes results from various experiments on the open string register of violins, comparing the vibrational response of Cremona violins and factory-made violins with in their Signature Modes.

### **Jürgen Meyer**

In a paper presented at the Stockholm Music Acoustic Conference in 1983, Jürgen Meyer attempted to show that it was “important to distinguish between the influence of

---

<sup>79</sup> Hamann, Donald L. and Robert Gillespie, *Strategies for Teaching Strings: Building a Successful String and Orchestra Program* (New York: Oxford University Press, 2004), 134.

<sup>80</sup> Beament, 10.

the player on the instrument and the acoustical properties of the instrument itself.”<sup>81</sup>

Meyer wanted to make a distinction between what the player had at his disposal to use, i.e. the bow, and the actual quality of the violin. He used one hundred violins for his comparison. Within the one hundred violins, six are made by Stradivari, and fourteen are made by other Old Italian Masters. He concludes that between 315 frequency (Hz) and 400 frequency (Hz), all the violins show the same frequency responses, and refers to this area of response as one of the strongest of the violin.<sup>82</sup> This supports the previously-sited research that concludes the note range between 190 Hz and 600 Hz on all violins responds with equal vibrational qualities, called the Signature Modes.

The following section supports research done on these Signature Modes. It is important to note that the height of the amplitude is what scientists use for measurement, and these measurements are used for comparison on all the violins.

### **Heinrich Dünwald**

German violinmaker, Heinrich Dünwald, conducted a study in 1991. He measured the acoustic response of (a) 10 master Italian violins, (b) 10 fine modern instruments, and (c) 10 cheap factory-made violins.<sup>83</sup> In figure 4.19, the measurement

---

<sup>81</sup> Neville Horner Fletcher and Thomas D. Rossing, *The Physics of Musical Instruments*, 2<sup>nd</sup> ed. (New York: Springer, 1998), 314.

<sup>82</sup> Fletcher, *Physics of Musical Instruments*, 315.

<sup>83</sup> Heinrich Dünwald, “Deduction of Objective Quality Parameters on Old and New Violins,” *Catgut Acoustical Society Journal* 1, no. 7 (July 1991): 3.

used to compare each instrument category is the height of the vibration response, not its width (thickness). The height measurement is not labeled on the left side of this figure, but each separate graph is measured the same, so the comparison can still be seen.

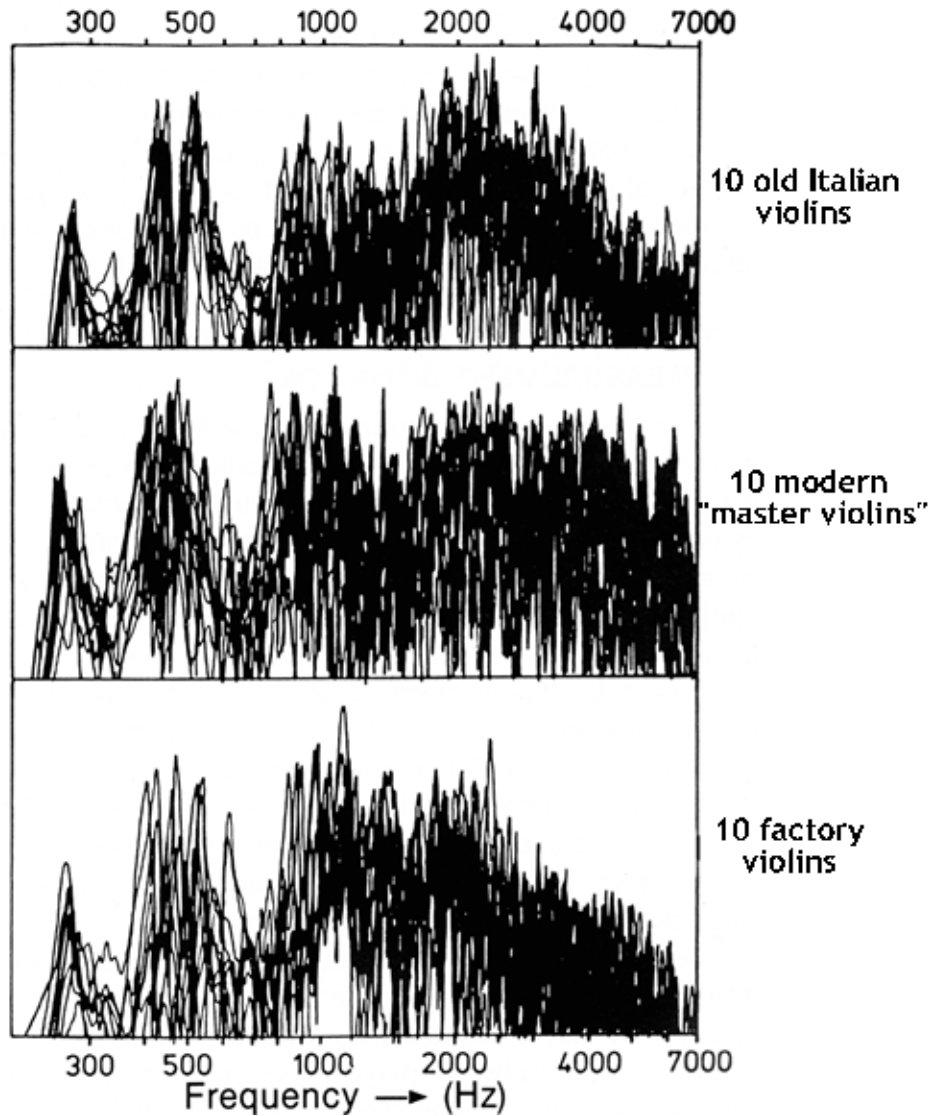

**Figure 4.19: Heinrich Dünwald Experiment** (Reprinted with permission from Heinrich Dünwald, "Deduction of Objective Quality Parameters on Old and New Violins," *Catgut Acoustical Society Journal* 1, no. 7 (May 1991): 3. Copyright 1991, Catgut Acoustical Society.)

Dünnwald concluded that between 400 and 600 Hz, the factory-made violins (C) were found, surprisingly, to be closer to the Old Italian instruments (A) than the modern copies (B). At frequencies above 1000 Hz, however, the factory-made instruments had a rather weak response, in contrast to the over-strong response of the modern violins, which may contribute to their shrillness.<sup>84</sup>

### **Eric Jansson**

Eric Jansson made a similar deduction in his study in 1995 using twenty-five high quality, prestigious instruments. The instruments all respond similarly within the 400 to 600 Hz range, but varied in response at both the higher and lower frequencies.<sup>85</sup>

### **Modern Swedish Violins**

In recent experiments in Sweden, violins made by three modern Swedish makers were compared to three Cremona violins: Stradivari, Gagliano, and Guaragnini. “All six instruments were played by two professional players and the sound judged and scored by an audience comprised of members from the European String Teacher's Association. A

---

<sup>84</sup> Dünnwald, 3.

<sup>85</sup> Eric Jansson, “Admittance Measurements of 25 High Quality Violins,” *Acustica* 83, no. 2 (March-April 1997): 338.

modern violin by Peter Westerlund obtained the highest score.”<sup>86</sup> Violinmakers are making great headways in matching the Cremona instruments. Their knowledge on Signature Modes has narrowed the differences.

### **American Cello Congress**

At the Fourth American Cello Congress in 1990, a double blind test was organized by Robert Cauer. “An audience of about 140 musicians judged the sound of twelve cellos: six new and six Cremona. The player is blindfolded and a linen screen used to hide the cellos from the audience. Instruments were only identified as new or old and the top-scoring cello was found to be old with the second, third, fourth, and fifth places going to new cellos.”<sup>87</sup>

In Chapter Five, master teachers Flesch, Galamian, Gerle, and Simon’s approach to teaching good tone-production will be analyzed.

---

<sup>86</sup> Alan Coggins, “Blind Faith,” *The Strad* 118, no. 1402 (February 2007): 53.

<sup>87</sup> Stan Schmidt, *Old Versus New in Cello Testing: The New and Improved Cello Test* (Elmhurst Illinois, 1991), <http://www.fritz-reuter.com/DOC/articles/other/oldvsnew.htm> (accessed August 10, 2008).

CHAPTER FIVE  
REVIEW OF THE LITERATURE:  
MASTER TEACHERS' TONE PRODUCTION PEDAGOGY

Tone production pedagogy of master teachers has been passed down over the decades in the private studio setting, one student at a time. Modeling is the dominate procedure for teaching tone-production. The master teacher demonstrates a good tone, and the students listen and match. Variations in tone-production or color as a tool of musical expression remain one of the most difficult skills for advanced violinists to master. How do master teachers teach tone-production? An examination of select master teachers can reveal patterns. These patterns can be studied and adapted for various string settings.

The tone-production pedagogies of Carl Flesch, Ivan Galamian, Robert Gerle, and Simon Fischer have been selected for this project. The criteria for selection is twofold: first, each has a comprehensive book or chapter within their book on tone-production; and second, their approach to teaching tone-production includes attention to bow-bridge distance, bow pressure, and bow speed. The latter criteria is in direct response to earlier-cited acoustics research.

## Carl Flesch

Carl Flesch's influence on modern violin playing is immense. Fortunately, he was a prolific writer, completing three volumes on violin pedagogy: *The Art of Violin Playing Book I*,<sup>1</sup> *The Art of Violin Playing, Book II: Artistic Realization and Instruction*,<sup>2</sup> and *Problems of Tone Production in Violin Playing*.<sup>3</sup> These publications are among the most comprehensive pedagogical books on violin technique.

Prior to writing *Problems of Tone Production in Violin Playing*, Flesch realized there was a disappointing trend in the newer “rational” teaching methods — an over emphasis on left hand technique.<sup>4</sup> The new pedagogies developed a high level of artistry, specifically in “precision and intonational purity,” but the “tonal accomplishments” have “retrogressed.”<sup>5</sup> According to Flesch, teaching left-hand technique is straightforward and mechanical, making it the natural focal point in a lesson.<sup>6</sup> Flesch is passionate about the possible reasons for this stating, “the primary cause for this is the fact that the more searching pursuits for mastery of finger technic [sic] have automatically relegated the

---

<sup>1</sup> Carl Flesch, *The Art of Violin Playing: Book I*, ed. Frederick Herman Martens (New York: NY, Carl Fischer, 1923) (revised 1939).

<sup>2</sup> Carl Flesch, *The Art of Violin Playing: Book II, Artistic Realization and Instruction*, ed. Eric Rosenblith (New York: Carl Fischer, 1930).

<sup>3</sup> Carl Flesch, *Problems of Tone Production in Violin Playing*, tran. Gustav Saenger (New York: Carl Fischer, 1934).

<sup>4</sup> Flesch, *Problems of Tone*, 5.

<sup>5</sup> Flesch, *Problems of Tone*, 5.

<sup>6</sup> Flesch, *Problems of Tone*, 5.

tonal element to second place.”<sup>7</sup> The secondary reason, according to Flesch is due to “poplar music,” and its focus on providing the listener with an “agreeable, inoffensive tickling of the ear.”<sup>8</sup> Flesch declares that, “dynamics . . . the vital nerve of tone-production . . . have become a non-essential in commercial music.”<sup>9</sup> Therefore, it was vital for him to publish his third book, *Problems of Tone Production in Violin Playing*, which focuses entirely on the mechanics of the violinist’s right hand and arm.

Flesch’s explanation of tone-production is parallel to a physicist. Anders Askenfelt and Jim Woodhouse described the importance of producing the Helmholtz corner on the vibrating bowed-string to allow the strongest fundamental note, which in turn produces an abundance of harmonic upper partials. Flesch describes tone-production as follows:

tone production is governed by equally restricted, though infinitely more complicated mechanical laws, than those of pitch, in which a mathematically established number of vibrations constitutes the only deciding fact.<sup>10</sup>

This could be an introduction to a discussion on the Helmholtz Motion and its effect on tone, although Flesch never uses that term.

---

<sup>7</sup> Flesch, *Problems of Tone*, 5.

<sup>8</sup> Flesch, *Problems of Tone*, 5.

<sup>9</sup> Flesch, *Problems of Tone*, 5.

<sup>10</sup> Flesch, *Problems of Tone*, 6.

Carl Flesch is specific in his discussion of five points of contact in, *The Art of Violin Playing*.<sup>11</sup> Flesch divides the area of the strings between the bridge and the fingerboard into five bow “points of contact.”<sup>12</sup> Flesch uses the term “points of contact theory,” and provides the following description to each of the five areas between the bridge and the fingerboard of the violin.

- I. At the bridge (Br.)
- II. In the neighborhood of the bridge } (Brn.)  
(between bridge and central point)
- III. At the central point (Cp.)
- IV. In the neighborhood of the fingerboard } (Fbn.)  
(between the fingerboard and central point)
- V. At the fingerboard (Fb.)

Flesch introduces abbreviations that can be used as a visual aid in the music, to help students organize their bow at the correct point to produce the optimal tone. The abbreviations could be placed throughout music very much like bowing symbols. Refer to figure 5.01 for his illustration.

---

<sup>11</sup> Flesch, *Violin Playing: Book I*, 62.

<sup>12</sup> Flesch, *Violin Playing: Book I*, 62.

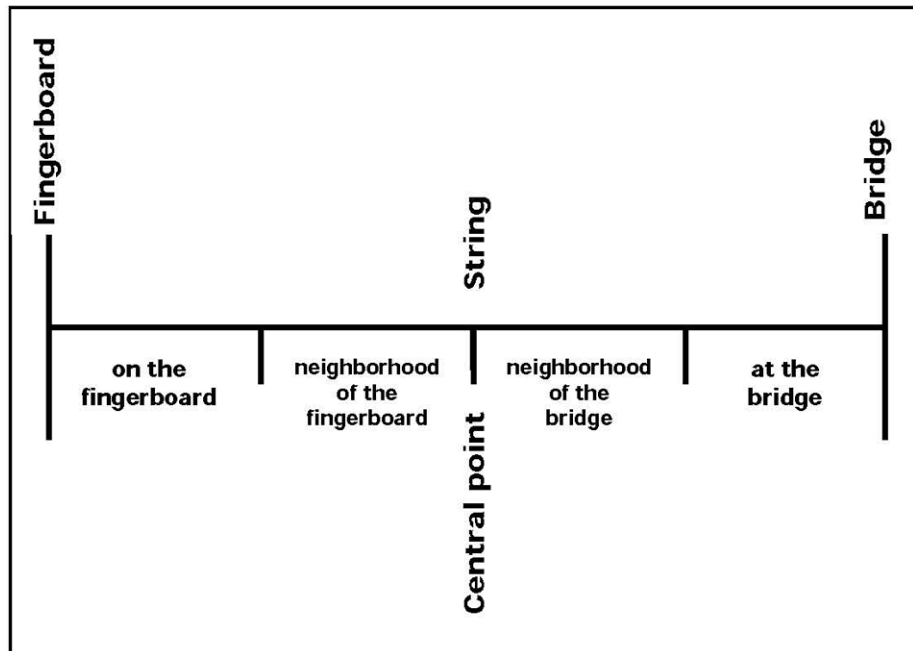

**Figure 5.01: Carl Flesch Point-of-Contact** (Carl Flesch, *Problems of Tone Production in Violin Playing* (New York: Carl Fischer, 1934), 5.)

Flesch states the importance of dividing the right-hand bow technique into two separate sections: the first is tone-production, the second is the mechanical aspects of the use of the bow and various bow strokes.<sup>13</sup> According to Flesch, “a tone is the result of regular, periodic vibration on a certain frequency.”<sup>14</sup> The string is set into motion by the bow hairs, which have “tiny little hooklets” that become “edgy” when the rosin is applied.<sup>15</sup>

<sup>13</sup> Flesch, *Violin Playing: Book I*, 62.

<sup>14</sup> Flesch, *Violin Playing: Book I*, 62.

<sup>15</sup> Flesch, *Violin Playing: Book I*, 62.

To obtain an unvarying tone, one should apply pressure to the first finger on the bow, and vary the speed depending on the duration of the length the note is held. However, Flesch continues by saying that in his opinion, the most important technique, and “the key to a tone production unimpeded by accompanying noises” is the point of contact between the bow hair and the string.<sup>16</sup> The technique of determining this optimal point of contact position, which is subject to constant change, occurs intuitively in advanced players, but needs to be taught at a very young age. Because learning this technique is the key to mastering tone-production, Flesch outlines tonal exercises to be practiced at a specific point of contact, and then requests the student play as “counter-proof,” at the opposite point of contact.<sup>17</sup> Allowing the student to hear the correct tone and the faulty tone one after another, enables the student to become familiar with which area of the string produces what type of sound for different types of notes, and apply the technique when a particular tone is called for by the composer.

Many teachers will focus on a correct bow-grip as the first step in tone-production. There is no doubt that the proper bow-grip is a necessary right-hand technique for students to learn, however, according to Carl Flesch, “well developed right [bow] arm mechanics does not necessarily insure corresponding tonal results.”<sup>18</sup> Flesch

---

<sup>16</sup> Flesch, *Violin Playing: Book I*, 62.

<sup>17</sup> Flesch, *Violin Playing: Book I*, 62.

<sup>18</sup> Flesch, *Problems of Tone*, 6.

is saying that to only focus on the bow-grip when teaching tone, is only a portion of the necessary techniques of tone-production. Therefore, teaching tone-production should be independent from, and in addition to, teaching the bow-grip. As proof of his statement, Flesch uses violinist Josef Szigeti as the example; observing that his bow technique was based on “obsolete [and] faulty fundamental principals.”<sup>19</sup> Yet, proclaiming his tone-production was surprising beautiful as a result of his “highly developed tonal sense, and cognizant of the secret of suitable tone-production . . . [plus his ability to] fit one to the other.”<sup>20</sup> Therefore, Flesch determines that tone-production is based more on the contact between the bow and the string, than on finger placement on the bow, or flexibility of the wrist and bow arm, which is traditionally the focal point on bow technique. Flesch’s statement, although contrary to the pedagogy of his string colleagues, does correspond with Schelleng’s description of where a bowed string vibrates most freely between the bridge and the fingerboard. As discussed in Chapter Four, the Schelleng Diagram displays at a glance, the region of “good behavior” for the bowed string model, i.e., the region of the parameter space in which simple Helmholtz Motion is obtained during a long, steady stroke.<sup>21</sup>

---

<sup>19</sup> Flesch, *Problems of Tone*, 6.

<sup>20</sup> Flesch, *Problems of Tone*, 6.

<sup>21</sup> John C. Schelleng, “The Bowed String and the Player,” *Journal of Acoustical Society of America* 53, no. 1 (January 1973): 28.

Flesch talks about teaching sound quality “exclusively from an aesthetic point of view.”<sup>22</sup> He warns that only using aesthetic terms to describe sound quality does not teach a student how to achieve that sound “mechanically” with the bow.<sup>23</sup> Flesch specifies that common descriptive words use when teaching tone quality are ones that are used by our senses, “sight, taste, smell, sense of touch and emotion.”<sup>24</sup> Terms such as, “bright or dull, clear or dark, full or hollow, large or thin,” only serve to guide interpretation.<sup>25</sup> Therefore, it is imperative that the visualization of a particular tone quality be supported by the appropriate “mechanical” information; the speed of the bow, the amount of pressure on the bow, and which point of contact should be used when teaching students.<sup>26</sup> Only the combinations of both “aesthetic and mechanical” teaching, will allow students to obtain the ability to learn a tone quality.<sup>27</sup> Flesch points out that position height of the left hand needs to be taken in to consideration when selecting bow pressure and point of contact. The string needs to vibrate purely and regularly to achieve its perfect sound, for that reason, when playing at the top of the fingerboard one must allow the greatest length of string to vibrate most freely. This is only possible by playing

---

<sup>22</sup> Flesch, *Problems of Tone*, 6.

<sup>23</sup> Flesch, *Problems of Tone*, 7.

<sup>24</sup> Flesch, *Problems of Tone*, 7.

<sup>25</sup> Flesch, *Problems of Tone*, 7.

<sup>26</sup> Flesch, *Problems of Tone*, 7.

<sup>27</sup> Flesch, *Problems of Tone*, 7.

lightly and on the strongest part of the string, point of contact one. Flesch states that when selecting the point of contact area of the string to place the bow for the “correct” sound, there are three factors that must be taken into consideration: (1) time duration of the stroke, (2) prescribed tonal volume, (3) height of position.<sup>28</sup> For these reason, the point of contact is “subject to constant change.”<sup>29</sup>

Flesch’s opinion is that the “quality of the instrument is not, as often asserted, a decisive factor in regard to tone-production. The latter, to begin with, is dependent upon the player himself.”<sup>30</sup> He adds that the quality of an instrument may at best assist the player to reach his endeavors, but that is all.

### **Ivan Galamian**

Ivan Galamian, the Iranian-American violinist represents a combination of the teachings of the Russian and French schools of violin technique, referred to as the Franco-Belgium school of violin technique. In Chapter Three of his treatise, *Principles of Violin Playing and Teaching*, Galamian reinforces what has been written in previous treatises concerning the importance of the interaction between bow speed, bow pressure,

---

<sup>28</sup> Flesch, *Problems of Tone*, 7.

<sup>29</sup> Flesch, *Problems of Tone*, 7.

<sup>30</sup> Flesch, *Problems of Tone*, 9.

and bow sounding point.<sup>31</sup> He refers to the right-hand of a violinist as having the most problems, and encourages the player to take a natural approach to solving these problems.

Galamian teaches that a perfectly natural and relaxed bow hold is the only way for a violinist to achieve a beautiful tone, and bases his approach to tone-production starting with the bow hold as its foundation. He encourages the player's bow hold to be in "constantly modification" as the bow travels up and down the string, changing speed and pressure through spring-like finger actions.<sup>32</sup> Galamian teaches that it is the bow that moves the fingers, encouraging his students to modify their bow hold based on their arm and finger length, and allow the bow to remain straight as it travels on the string, by letting the fingers adjust to its position. He stresses that the position of the bow stick form a forty-five degree angle to the plane of the string. Galamian asserts that having the bow at this angle when it travels on the string, will increase brilliance and give a more "free" tone quality (as opposed to "pinched" or "pressed").<sup>33</sup> This angle is considered especially important when approaching the frog of the bow.

Scientist Erwin Schoonderwaldt agrees with Galamian. He and his colleagues gave a lecture in 2003 on the subject of bow angle. A study was done to determine if "a

---

<sup>31</sup> Ivan Galamian, *Principles of Violin Playing and Teaching*, 3<sup>rd</sup> ed. (Englewood Cliffs: Prentice-Hall, 1985), 59.

<sup>32</sup> Galamian, *Principles of Violin Playing*, 45.

<sup>33</sup> Galamian, 59.

decrease of the width of the bow hair may boost the string spectrum considerably for higher harmonics.”<sup>34</sup> The results show that there is a gain in the harmonics amplitudes of three to six decibels, above harmonic twenty.<sup>35</sup> Decibel is “a unit for expressing the ratio of two amounts of electric or acoustic signal power.”<sup>36</sup> Therefore, if tone quality is “determined by the amplitudes of the harmonics,” then it seems to be true that there is an increase in brilliance, caused by the increase size in the harmonic upper partials.<sup>37</sup>

Galamian asserts that the final ingredient to produce a quality tone is “sounding point.”<sup>38</sup> He defines sounding point as the, “particular place, in relationship to the bridge, where the bow has to contact the string in order to get the best tonal results.”<sup>39</sup>

Different combinations of the three fundamental elements of tone-production; bow speed, bow pressure, and sounding point, are dependant on one another. Galamian gives examples of the importance of this interaction. For example, to produce a good tone a change in bow pressure may be required. Or, if the sound point remains constant there may need to be a change in bow speed.

---

<sup>34</sup> Schoonderwaldt, Erwin, Knut Guettler, and Anders Askenfelt, “Effects of the Width of the Bow Hair on the Violin String Spectrum,” (in *Proceedings of the Stockholm Music Acoustics Conference*, Stockholm, Sweden, 2003), 1, <http://www.speech.kth.se/> (accessed June 9, 2007).

<sup>35</sup> Schoonderwaldt, “Effects of Width of Bow Hair,” 1.

<sup>36</sup> Merriam-Webster on-line Dictionary, <http://www.merriam-webster.com/dictionary/Decibels> (accessed February 4, 2009).

<sup>37</sup> Beament, 10.

<sup>38</sup> Galamian, 55.

<sup>39</sup> Galamian, 55.

Galamian continues by describing the interaction of these three parameters, in the context of specific musical circumstances. If a rhythmic pattern requires changing bow speed, pressure must be adjusted to compensate for the variation in dynamic. A rhythmic example of this can be a group of slurred notes followed by one note that is not. When this pattern is in a repetitive phrase, special care needs to be given to the single note so that it is not louder than the group of slurred notes. Similarly, to keep a constant dynamic within a long, slow stroke, pressure must be adjusted to keep the tone even, because of the naturally varying amount of force along the length of bow.<sup>40</sup> Referring to the bow as a lever, Galamian suggests that it be treated as such. He stresses that the bow itself, is made up of varying weights, heavier at the frog than at the tip, and it changes in degrees as it travels up and down. Therefore, a constant amount of pressure will result in an unequal pressure on the string. Awareness is needed to change the pressure on the bow, so that a consistent dynamic in tone can be achieved from one end of the bow to the other. Galamian uses checks and balances when describing a certain tone that is needed for a section of music. Very much like Carl Flesch, he suggests that particular exercises be done at the opposite extreme. In order for the student to become familiar with the specific tone needed for a particular passage, Galamian suggests the student play at opposite sounding points. He adds that a “player whose ear is not keen or not alert

---

<sup>40</sup> Galamian, 55.

enough to guide him to the best sounding point, or whose bow technique does not allow him to follow his ear, will of course, never achieve satisfactory tone production.”<sup>41</sup> He continues by suggesting that attentiveness in slow practice can cleanup many of the discrepancies in bow technique.

Galamian states that the key to mastering tone-production is the ability to learn the bow technique of changing from one sounding point to another smoothly. He suggests that students begin close to the fingerboard and “glide” the bow toward the bridge in a “pulling action,” keeping the bow parallel to the bridge.<sup>42</sup> Then to reverse this glide motion by starting the bow at the bridge and pushing it towards the fingerboard. He warns that when pulling or pushing the bow, that the stick remains in a forty-five degree angle to the plane of the string as it travels.

Galamian’s bowing method makes use of the fact that a stroke that is moving slightly non-parallel to the bride will permit the bow to slide towards or away from the fingerboard, “depending upon the oblique direction it assumes.”<sup>43</sup> The bow is able to travel this way because Galamian believes that in order to get a good tone at not too great of speed, the bow needs to be in an “extremely” slight angle with the bridge.<sup>44</sup> This means that as the bow travels on the string, the point is always a little closer to the

---

<sup>41</sup> Galamian, 59

<sup>42</sup> Galamian, 59.

<sup>43</sup> Galamian, 59.

<sup>44</sup> Galamian, 61.

fingerboard, and the frog it always a little closer to the bridge. This is what Galamian refers to as “the slightly slanted stroke.”<sup>45</sup> Ideally, the bow should travel on the same “identical path” in both directions, and always with the bow stick at a right angle facing towards the fingerboard.<sup>46</sup>

When teaching variations in tone-production, Galamian simplifies his approach to cover just two opposites types of dynamics. “Type One relies mainly on speed to bring out the [piano] dynamic differences required in the music; consequently, much bow will be used without too much pressure.”<sup>47</sup> The sounding point will be closer to the fingerboard. “Type Two relies mainly on pressure, [forte] which will be used in a combination with a rather slow speed in the bow,” and the sounding point will be closer to the bridge.<sup>48</sup> Galamian uses colors to help define these areas; Type One, is described as a “paler, more delicate and pastel-like,” Type Two, as being the brightest of colors.<sup>49</sup>

## **Robert Gerle**

In his book, *The Art of Bowing Practice: The Expressive Bow Technique*, Robert Gerle refers to the scientific principals of acoustics when discussing producing a good

---

<sup>45</sup> Galamian, 61.

<sup>46</sup> Galamian, 61.

<sup>47</sup> Galamian, 62.

<sup>48</sup> Galamian, 62.

<sup>49</sup> Galamian, 62.

tone.<sup>50</sup> He states that although there are many, “legitimate and successful approaches to the art of bowing . . . certain mechanical, physical, physiological, and acoustical rules are constant and beyond dispute.”<sup>51</sup> Gerle also observes that many young musicians do not spend the time needed to acquire the skill needed to express the concept of musical expression. There are distinct ways that tone conveys what expressive content is produced within music. Learning to implement the correct bow techniques to convey this expression, should be a portion of each lesson. Without this direction, students hope, “that mere repetition will miraculously bring out the desired effect.”<sup>52</sup> In the introduction, Gerle discusses the reasons for writing his book, saying that contemporary string methods have become focused around left hand technique. Interestingly, he links the problem in developing bowing technique to the demand for instant progress and solutions.<sup>53</sup> Developing right-hand technique can be a slow process, and within societal desire for instant success, it is much more natural to focus on the mechanics of the left-hand.

Gerle states that there are only two elements required for producing good tone: the mechanical and the physiological. “The bow provides the first, the player the

---

<sup>50</sup> Robert Gerle, *The Art of Bowing Practice: The Expressive Bow Technique* (London: Stainer & Bell, 2004), 15.

<sup>51</sup> Gerle, 15.

<sup>52</sup> Gerle, 15.

<sup>53</sup> Gerle, 11.

second.”<sup>54</sup>

The three fundamental variables in producing good tone quality:

1. bow-speed
2. bow-pressure
3. distance from the bridge

These three fundamental variables are dependent on each other for a given output in dynamics. These are fully independent variables the player can use in order to obtain a particular outcome of tone color. Knowing which dynamic and color to execute is the artist’s decision. Choosing which variables to adjust is also the artist’s decision. Gerle states, “bow-speed and bow-pressure are inversely proportionate at the same dynamic level, and the distance of the bow from the bridge depends on their interrelation.”<sup>55</sup> He continues by stating, “they change in proportion to each other, but their sum total remains constant on a given, steady dynamic level.”<sup>56</sup> To help students learn to implement and adjust for varying dynamic outcomes, Gerle provides an innovative visual image of balloon-like circles, to show how different proportions of bow speed, bow pressure, and bow distance from the bridge, can produce the dynamic ranges between piano and forte. The smallest size balloons are piano (p), the middle size balloons are mezzo forte (mf),

---

<sup>54</sup> Gerle, 43.

<sup>55</sup> Gerle, 43.

<sup>56</sup> Gerle, 43.

and the largest size balloons are forte (f). In figure 5.02, the balloons on the left show proportions needed for a sustained dynamic level. As the dynamic level increases, so does the size of the balloon. The balloons on the right show proportions for a sudden change in dynamic level, which change in size based on dynamic level.<sup>57</sup> The variations in proportions of these elements represent how the player obtains that dynamic level. These balloons can be used as a visual aid for students when playing sudden dynamic changes, by selecting two different size balloons. For example, when sustaining forte (f), to achieve a sudden piano (p), the left forte (f) balloon proportions need to change in comparison with the right piano (p) balloon proportions.

---

<sup>57</sup> Gerle, 44.

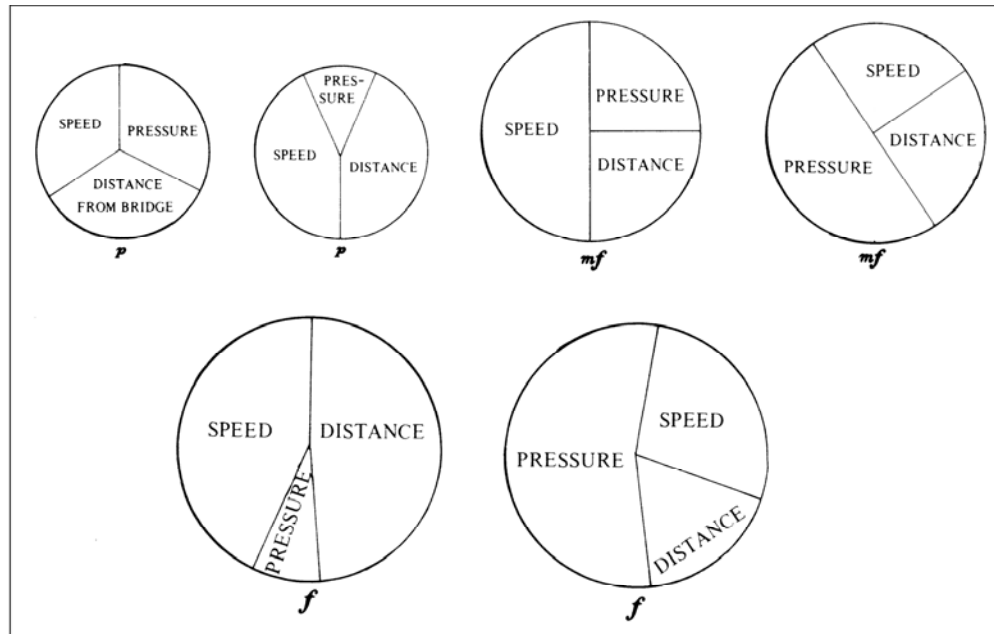

**Figure 5.02: Robert Gerle: Bowing Elements in Varying Proportions** (Robert Gerle, *The Art of Bowing Practice: The Expressive Bow Technique* (London: Stainer & Bell, 2004), 44, Stainer & Bell. Reproduced from 'The Art of Bowing Practice' by Robert Gerle by permission of Stainer & Bell Ltd, London England [www.stainer.co.uk](http://www.stainer.co.uk).)

Gerle further demonstrates this technique further with these examples: the greater the bow-speed, the lesser the bow-pressure, the greater the distance from the bridge, or the lesser the bow-speed, the greater the bow-pressure, the lesser the distance from the bridge. Gerle states it is important to make a distinction between the pressure on the string resulting from the bow itself, which is referred to as 'weight' or 'gravity', and the pressure placed on the bow from the player, referred to as 'force' or 'power'.<sup>58</sup> The difference in the use of the word pressure in this case, can be demonstrated by pulling the

---

<sup>58</sup> Gerle, 44.

bow across the string from the frog to the tip maintaining the same bow-speed, distance from the bridge, and the same dynamic. To keep a consistent dynamic, one needs to add more pressure to the bow as it travels towards the tip, given that the weight of the arm is not directly over the bow and the weight of the bow at the tip is much less than at the frog of the bow. Conversely, when the bow travels from the tip to the frog, the pressure needs to be released as it travels back to the frog to maintain the same dynamic level. Gerle describes this as applying either a positive or a negative force on the bow depending on where you are along the bow.

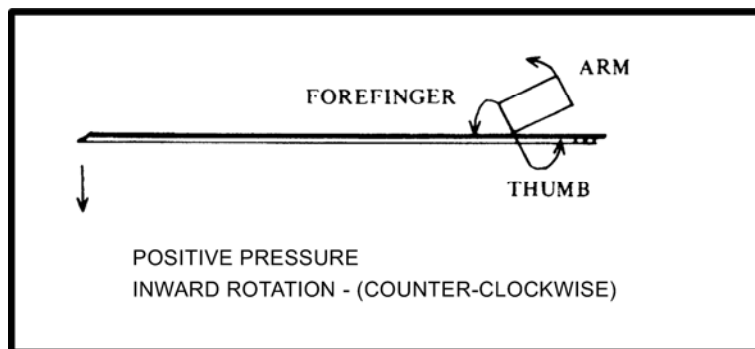

**Figure 5.03a: Positive Pressure** (Reprinted with permission from Robert Gerle, *The Art of Bowing Practice: The Expressive Bow Technique* (London: Stainer & Bell, 2004), 45, (left side). Copyright 2004, Stainer & Bell. Reproduced from 'The Art of Bowing Practice' by Robert Gerle by permission of Stainer & Bell Ltd, London England [www.stainer.co.uk](http://www.stainer.co.uk).)

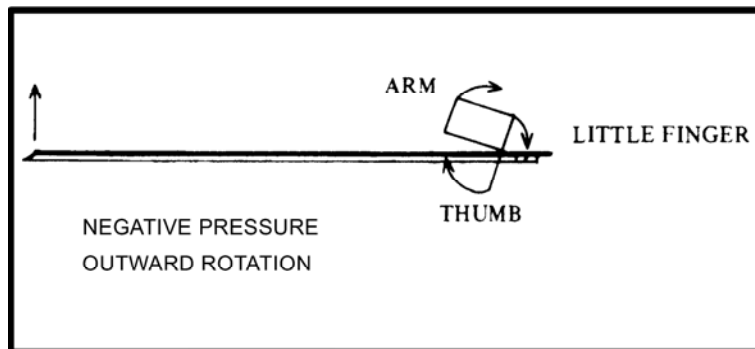

**Figure 5.03b: Negative Pressure** (Reprinted with permission from Robert Gerle, *The Art of Bowing Practice: The Expressive Bow Technique* (London: Stainer & Bell, 2004), 45, (right side). Copyright 2004, Stainer & Bell. Reproduced from *The Art of Bowing Practice* by Robert Gerle by permission of Stainer & Bell Ltd, London England [www.stainer.co.uk](http://www.stainer.co.uk).)

This positive and negative pressure comes from creating the feeling of a lever between the thumb and first finger on the bow grip.<sup>59</sup>

To reinforce his lever concept, Gerle suggests using a small postal balance to learn how where in the bow there needs to have more positive or negative pressure.<sup>60</sup> Bowing along the edge of the postal balance, keeping it at a steady four ounces, will transfer to a dynamic marking of mezzo forte. If no additional pressure is applied, then the postal balance will register only one-half ounce when it stops at the very tip. The following exercise comes from Gerle's book; *The Art of Bowing Practice: The Expressive Bow Technique*:

1. Hold the balance as if it were a violin

---

<sup>59</sup> Gerle, 45.

<sup>60</sup> Gerle, 46.

2. Move the bow in a normal way on the right edge of its platform, starting at the frog and using its weight, plus a small amount of arm-weight, adding up to 4 ounces shown on the scale, equal to *mf*.
3. Move the bow towards the tip with no increase in pressure.
4. The amount shown on the scale will diminish until at the tip will be no more than  $\frac{1}{2}$  ounce.
5. If you now try to maintain the same pressure at four ounces, it will be clear that considerable torque is needed for the necessary increase in pressure.<sup>61</sup>

Gerle advocates that this exercise is an excellent way to grasp that a considerable amount of “torque pressure” is required to maintain a mezzo forte at the tip.<sup>62</sup>

Gerle believes there is an important physiological principal to playing a string instrument. He states, “as in sport or any other physical activity, the best results with the least effort are achieved by using muscles which are proportionate to the task: larger, stronger muscles for the greater physical effort, smaller ones for the more delicate actions.”<sup>63</sup>

---

<sup>61</sup> Gerle, 46.

<sup>62</sup> Gerle, 46.

<sup>63</sup> Gerle, 47.

## **Simon Fischer**

Simon Fischer, a former student of Dorothy Delay at the Julliard School, is the author of *Basics: 300 Exercises and Practice Routines for the Violin*,<sup>64</sup> and *Practice: 250 Step-by-Step Practice Methods for the Violin*.<sup>65</sup> Fischer also studied the violin in London with Yfrah Neaman, whose teachers were Carl Flesch and Max Rostal. Since 1982, Fischer has taught violin at the Guildhall School of Music and Drama in London. In 1997, he expanded his teaching to include the Yehudi Menuhin School. Fischer holds master classes each year in England, the United States, and Australia. Many of these master classes are video taped, and available on YouTube. Fischer's innovative use of the Internet provides teachers with a magnitude of teaching resources on tone-production, thus, allowing teachers to hear and see many of the tone-production exercises he outlines in his books. He is currently in the process of writing a new book called *The Violin Lesson*. This book will include a DVD of the master classes he has held, and will provide valuable resources for teaching tone-production.

---

<sup>64</sup> Simon Fischer, *Basics: 300 Exercises and Practice Routines for the Violin*, ed. Hinrichsen (London: Peters Edition Limited, 1997).

<sup>65</sup> Simon Fischer, *Practice: 250 Step-by-Step Practice Methods for the Violin*, ed. Hinrichsen (London: Peters Edition Limited, 2004).

Simon Fischer defines the fundamental characters of tone-production:

Every sound is the result of: (1) a particular speed of bow with (2) a particular amount of pressure . . . dependent on (3) the tension of the string at that particular distance from the bridge . . . at every distance from the bridge there is a certain amount of speed, combined with a certain amount of pressure that produces the freest and, when wanted the widest possible vibration of the string.<sup>66</sup>

Executed with proficiency and in varying combinations, the bow is responsible for the distinct qualities of color and texture. The understanding that tone quality is a product of these three components is not new. What is new, are the innovative ways Fischer simplifies the concept, to help facilitate an awareness of first the parts, then the entire technique.

Fischer understands that, “players and teachers avoid using the word 'pressure' because they fear that it may lead to pressing the bow, [so] they use the word 'weight' instead, to encourage a feeling of sinking the weight of the bow into the string.”<sup>67</sup> Fischer feels that if particular attention is given to the fingers’ distribution on the bow, and one is focused on proper balance between bow pressure, bow speed, and bow distance from the bridge, then using the word ‘pressure’ is fine. He goes on to state that it is important to

---

<sup>66</sup> Fischer, *Practice*, 47.

<sup>67</sup> Simon Fischer, “Tone Production,” *The Strad* 119, no. 1420 (2008):76.

have a “conception of the freely vibrating string, of the purity, and beauty of tone that you want, the exact musical expression and phrasing, and [as] you listen — then there is little danger of playing with a pressed tone.”<sup>68</sup>

Fischer finds that, “it is all too easy [for students] to bow near the fingerboard too much of the time, because this is the line of least resistance. Unless you deliberately move the bow against this line, the bow automatically moves to the fingerboard.”<sup>69</sup>

According to Fischer, the sound created close to the fingerboard may sound “mellow’ to the player’s ear “because there are fewer upper partials in the sound.”<sup>70</sup> However, lacking these (harmonic) upper partials means “the tone will lack brilliance and carrying power.”<sup>71</sup> This particular statement is descriptive, yet not completely factual. The important distinction is, notes are compound, therefore contain harmonic upper partials, however, the quality its tone is “determined by the amplitudes (size) of the harmonics which are present.”<sup>72</sup>

To help students learn the correct amount of pressure needed to play with a rich

---

<sup>68</sup> Fischer, “Tone Production,” (2008), 76.

<sup>69</sup> Simon Fischer, “Some Essential Aspects of the Bow and Bow Arm,” *The Strad* 106, no. 1264 (August 1995): 800.

<sup>70</sup> Fischer, “Essential Aspects,” 800.

<sup>71</sup> Fischer, “Essential Aspects,” 800.

<sup>72</sup> Beament, 10.

tone, Fischer suggests using the natural spring of the bow, and suggests the following exercise:

1. Place the bow on the string without moving it, and push the stick towards the hair.
2. The bow will want to spring back to a relaxed state if a sustained pressure is not maintained.
3. By resisting the bow's upwards push, and adjusting the speed and sounding point, students will learn the correct combination of speed and sounding point that will make the richest tone.

Fischer states that, “one of the first things children must learn about the use of the bow is to play down into the springiness of the stick rather than only move the hair of the bow along the surface of the string.”<sup>73</sup>

Fischer describes five areas between the bridge and the fingerboard in detail — referring to them as the “soundpoints” of bowing. He uses Flesch's definition for clarification, provides a photo of the top of a violin to further clarify the five positions of the bow, and he numbers each position, one through five; number one being closest to the bridge and number five being at the fingerboard.

---

<sup>73</sup> Simon Fischer, “Playing into the Wood of the Bow,” *The Strad* 118, no. 1401 (January 2007): 66.

Fischer's suggestion to add this numbering system to his definition of soundpoints creates an opportunity for string music educators to effortlessly incorporate this bowing technique into any and all teaching situations. Fischer also presents a very simple and "effective first step" in teaching the characteristics of each of the bow's soundpoints to young students without using the bow.<sup>74</sup> He outlines his concept as follows:

An effective first step for elementary students is for them to press the string down with their index finger (i.e. without the bow), first on soundpoint five and then again on soundpoint one. Gently pressing and releasing the string a few times makes the tension and elasticity immediately clear; looser and softer sound on soundpoint five; tighter and harder on soundpoint one. The student should then play a few simple strokes on the same soundpoints 'feeling' the string with the hair of the bow instead of the index finger.<sup>75</sup>

Below is Fischer's description of placement for the five soundpoints of the bow and a photo.<sup>76</sup> Divide the area from the bridge to the fingerboard into five 'soundpoints':

1. Near the bridge
2. Between the bridge and the central point
3. At the central point

---

<sup>74</sup> Fischer, *Basics*, 41.

<sup>75</sup> Fischer, *Basics*, 41.

<sup>76</sup> Fischer, *Basics*, 41.

4. Between the central point and the fingerboard
5. At the fingerboard

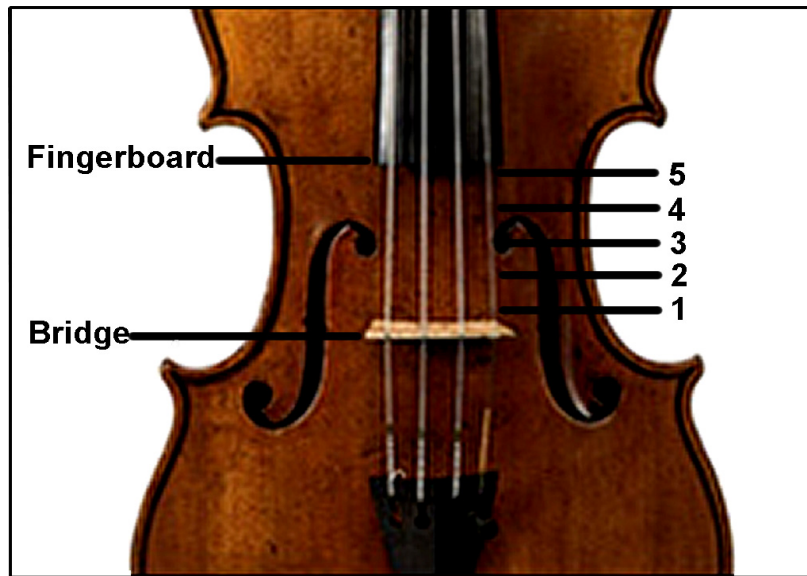

**Figure 5.04: Simon Fischer — Soundpoint** (Author's violin pictured, original photograph in, Simon Fischer, *Basics: 300 Exercises and Practice Routines for the Violin*, ed. Hinrichsen (London: Peters Edition Limited, 1997), 41.)

Fischer illustrates each contact point, using the term sounding point, between the bridge and fingerboard. Each is numbered beginning with number one closest to the bridge.

Placing the bow at different contact points will change the color of the notes. The contact point closest to the fingerboard produces a soft, translucent sound, while the contact point closest to the bridge produces a loud, harsh sound.<sup>77</sup>

---

<sup>77</sup> Fischer, *Practice*, 47.

These four master teachers have distinct approaches for teaching good tone-production; yet, they are consistent in their message. Producing good tone depends on the player's ability to control and balance the combination of bow speed, bow pressure, and bow placement between the bridge and the fingerboard. Bow speed, bow pressure, and sounding point are not independent of each other; they have to be used in appropriate combination.

The final section of this chapter is an investigation into the popular and readily available string method books, published specifically for the heterogeneous string classroom. How do these books teach tone-production in the general string classroom setting at the elementary and secondary levels?

### **Widely Used Approaches to Teaching Tone-Production**

Teaching string students in a heterogeneous group setting can be challenging. Many gifted teachers have shared their insights by publishing their successful teaching strategies in books, geared specifically for the public school heterogeneous classroom setting. In these commonly used books many topics are covered; from how to successfully start, build, and maintain a strong string program; to resourceful ideas for helping teachers teach left-hand technique; holding the instrument and bow; and note reading. Unfortunately, they do not generally present a clear method for teaching good tone-production. The working assumption is a probable reliance on modeling.

## Strictly Strings

Many school strings programs use *Strictly Strings*.<sup>78</sup> The teacher's manual is filled with wonderful teaching ideas dispersed in easy to find boxes. In one of these boxes Dillon writes in bold, "Vibration Equals Tone."<sup>79</sup> She reminds teachers, "to point out that the width of the string vibration is a direct reflection of tone quality."<sup>80</sup> Dillon says that the bigger the "vibration pattern, the better the sound!"<sup>81</sup> She says, "students can also be taught to 'feel' a good tone . . . [and] . . . it will motivate students to play with a straight bow."<sup>82</sup> Dillon talks about bow speed, and teaches that students will need to use, "twice as much bow for the half note than the quarter note, and vice versa."<sup>83</sup> Dillon introduces dynamics, by saying to "teach the students to use more (*faster*) bow and more weight into the string" when playing forte, and use "less (*slower*) bow and less weight into the string" when playing piano.<sup>84</sup> She encourages teachers to "rote work" on open strings to master this technique, and to remember, "it takes time to be able to control these dynamic changes without sacrificing tone quality."<sup>85</sup> Dillon has introduced all

---

<sup>78</sup> Jacquelyn Dillon, James Kjelland, and John O'Reilly, *Strictly Strings: A Comprehensive String Method, Book I, Teacher Manual* (Van Nuys, CA: Highland/Etling, 1992).

<sup>79</sup> Dillon, *Strictly Strings*, 73.

<sup>80</sup> Dillon, *Strictly Strings*, 73.

<sup>81</sup> Dillon, *Strictly Strings*, 73.

<sup>82</sup> Dillon, *Strictly Strings*, 73.

<sup>83</sup> Dillon, *Strictly Strings*, 79.

<sup>84</sup> Dillon, *Strictly Strings*, 123.

<sup>85</sup> Dillon, *Strictly Strings*, 123.

three components of tone production by page twenty-three in the student book. Although the directions are clear and specific, this approach does not go far enough beyond modeling.

### **Superstart: Basic Skills and Pieces for Beginners**

This book is designed for teaching a homogeneous beginning string class. In *Superstart Violin Level I: Basic Skills and Pieces for Beginners*, Mary Cohen has the students learn and play a song called, “The Good Sound Guide.”<sup>86</sup> The words of the song include, “if you grip you’ll make a scitchy scratchy sound ... flex your fingers and your thumb, please, and the sound will just come out.”<sup>87</sup> There are two addition verses, “too much rosin makes an itty gritty sound ...” and, “if you skid you’ll make an eaky squeaky sound.”<sup>88</sup> With this song, Cohen is using Galamian’s approach to teaching tone-production, which is that tone-production is based on a student’s bow hold.<sup>89</sup> There are no other references, other than defining pianissimo and forte, having to do with teaching tone-production.

---

<sup>86</sup> Mary Cohen, *Superstart Violin Level I: Basic Skills and Pieces for Beginners* (London: Faber Music, 1997), 16.

<sup>87</sup> Cohen, 16.

<sup>88</sup> Cohen, 16.

<sup>89</sup> Galamian, 59.

## Essential Elements 2000

In *Essential Elements 2000 for Strings*, the authors have “listening skills” exercises throughout their book, which can be used to encourage students to produce a good sound.<sup>90</sup> The exercise is for the student to repeat what the teacher plays first. This approach to teaching tone-production may echo the Suzuki method. The Suzuki books include a tape-recording of all the pieces the students will learn. Students are instructed to listen to the pieces as part of their practice. This is the important element in teaching tone production in the Suzuki method.<sup>91</sup> Traditionally, tone-production is taught through modeling, therefore, this may be the author’s approach for encouraging teachers to model the correct tone-production for their students.

## New Directions for Strings

One of the most recent string method books (the collaborate work of Joanne Erwin, Kathleen Horvath, Robert McCashin, and Brenda Mitchell) is *New Directions for Strings: A Comprehensive String Method Book*.<sup>92</sup> Book II was published in 2008, and

---

<sup>90</sup> Michael Allen, Robert Gillespie, and Pamela Tellejohn Hayes, *Essential Elements 2000 for Strings: A Comprehensive String Method, Book One, Teacher’s Manual* (Milwaukee MN: Hal Leonard, 2002), 65, 95, 139, 173, 179, 196, 207, 215.

<sup>91</sup> Shinichi Suzuki, *Violin School: Violin Part, Vol. 1* (Van Nuys: Alfred Publishing, 1978).

<sup>92</sup> Joanne Erwin and others, *New Directions of Strings: A Comprehensive String Method Teacher’s Manual Book II*, ed. B. Balmages (Fort Lauderdale: The FJH Music Co, 2008), 82.

continues with the format of Book I. The Teacher's Manual for Book II will be published early 2009.

In *Book I, Unit 4: Meeting the Bow*, the authors prepare the teacher for teaching tone-production by examining the three proprieties that need to be present, “speed, weight, and sounding (contact) point.”<sup>93</sup> These are defined as:

1. Speed – the rate of motion of the bow as it is drawn across the string. This is controlled by the whole arm, wrist, and hand.
2. Weight – the amount of force exerted on the string by gravity's effect on the arm. This is more of release of inherent arm force rather than the application of “pressure.” The concept of released weight is important to prevent tension in the right arm.
3. Sounding (contact) point – this is the actual point of contact between the bow and string, relative to the bridge . . . <sup>94</sup>

There is an additional description of the area between the bridge and the fingerboard, and that is that this area contains various ‘lanes’ that run parallel to the bridge for the bow to travel on. The term “lane” has been used by many string educators, one of whom is Robert Gillespie in his book, *Strategies for Teaching Strings*, and serves

---

<sup>93</sup> Erwin, 82.

<sup>94</sup> Erwin, 82.

as a visual aid for students.<sup>95</sup> Erwin continues to describe the meaning of “lanes” by adding an illustration showing “bowing variables of speed and weight.”<sup>96</sup> This illustrates how the different tone qualities are achieved, see figure 5.05.

<b>Fingerboard</b>		
<b>Lane 1:</b>	<b>Speed: 5</b>	<b>Weight: 1</b>
<b>Lane 2:</b>	<b>Speed: 4</b>	<b>Weight: 2</b>
<b>Lane 3:</b>	<b>Speed: 3</b>	<b>Weight: 3</b>
<b>Lane 4:</b>	<b>Speed: 2</b>	<b>Weight: 4</b>
<b>Lane 5:</b>	<b>Speed: 1</b>	<b>Weight: 5</b>
<b>Bridge</b>		

**Figure 5.05: New Directions for Strings: Bowing on the Instrument** (Reprinted with permission from Joanne Erwin and others, *New Directions for Strings: A Comprehensive String Method Teacher Manual Book I*, ed. B. Balmages (Fort Lauderdale: The FJH Music Company, 2007), 83. Copyright 2007, FJH Music Company. )

The authors go on to point out that lanes two and four, are the most frequently used with lanes one and five, “reserved for color bowings such as *sul tasto* (bowing over the fingerboard) or *sul pointicello* (bowing near the bridge).”<sup>97</sup> There is no clear

---

<sup>95</sup> Hamann, 65.

<sup>96</sup> Hamann, 83.

<sup>97</sup> Hamann, 83.

definition of when to use lane three.

Throughout the book, the authors continue to remind teachers about the “Bow Lanes (Point of Contact)” in their Unit Skill Summary, as well as in the green-boxed “Teacher Tip” sections.<sup>98</sup> Unit Four focuses on “Bow Lanes” in reference to teaching dynamics, and introduces the three components of tone-production; “Speed, Weight, and Contact Point (Location).”<sup>99</sup> The different lanes are described as the “piano Lane, near the fingerboard,” and the “forte Lane, near the bridge.”<sup>100</sup> The authors also instruct teachers to have students “add slightly more weight and less speed” when playing on the forte Lane, and “slightly more speed and less weight” when playing on the piano Lane.<sup>101</sup> Unit Eight, discusses bow distribution by introducing bow speed. The authors discuss the bow technique of adding or subtracting bow speed in order to be able to continue to use full bows on all notes being played.<sup>102</sup> These exercises in Unit Eight encourage students to learn bow division and playing faster and longer bows on short notes when a long note follows, therefore, not running out of bow for the long note. Unit Ten: Advanced Musicianship, reinforces the three components of tone-production.<sup>103</sup> “Good Sound, Big

---

<sup>98</sup> Hamann, 97, 104.

<sup>99</sup> Hamann, 97.

<sup>100</sup> Hamann, 97.

<sup>101</sup> Hamann, 97.

<sup>102</sup> Hamann, 168.

<sup>103</sup> Hamann, 231.

Tone = the correct combinations of bow speed, arm weight, and contact point (bow lane).”<sup>104</sup>

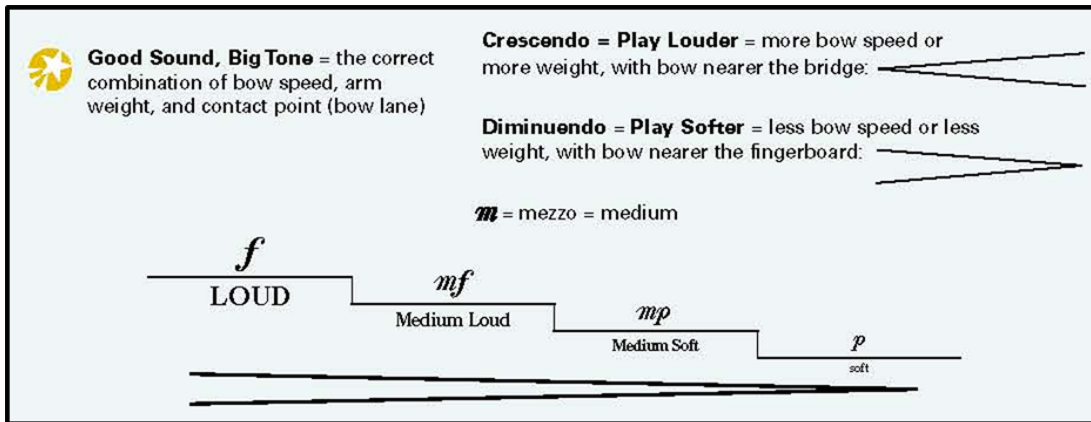

**Figure 5.06: Good Sound, Big Tone** (Reprinted with permission from Joanne Erwin and others, *New Directions of Strings: A Comprehensive String Method Teacher’s Manual Book I*, ed. B. Balmages (Fort Lauderdale: The FJH Music Company, 2008), 231. Copyright 2007, FJH Music Company.)

Again, the most readily perceived parameters of sound are the focus of this unit for teaching the components of tone-production. The important factor is that these authors have made an effort to pass on master teachers’ philosophy of tone-production.

String books traditionally hesitate to use the term “bow pressure” when teaching bow techniques. Galamian is clear that terms such as “gravity” and “arm-weight” be used whenever possible when teaching bow techniques.<sup>105</sup> Unfortunately, teachers who

<sup>104</sup> Hamann, 231.

<sup>105</sup> Simon Fischer, “Tone Production,” *Strad* 119, no. 1420 (August 2008): 76-77.

are using method books in their classrooms may not get the same results that Galamian would have gotten in his private studio. Using Galamian terms, “gravity” and “arm-weight,” to a group of students might very well create more confusion than clarification, in that gravity and arm weight do not change. Using the term “pressure” may be a more recognizable word for young students that describe exactly what needs to happen for the bow to generate enough friction to produce Helmholtz Motion in the string.

Many contemporary method books start with learning the names of the open string notes, and have students play only pizzicato for the first few weeks of classes. Jacquelyn Dillon-Krass, author and authority on string pedagogy at Wichita State University, advocates having students start pizzicato because, “[then] they are able to play tunes right away and feel successful.”<sup>106</sup> This is true, because when a student plucks an open string, there are not many things that can go wrong; the string vibrates freely and produces a pleasant sound instantly. This is because a plucked string is a linear system, which means the vibrations from the string produce a single response function. This means that when the string is plucked twice as strong, the ear will hear the same pitch twice as loud.<sup>107</sup> On the other hand, when a student bows an open string, many different outcomes can be produced. It is considered a non-linear system. This means that when

---

<sup>106</sup> Jacquelyn Dillon-Krass, *String Class Teaching Philosophy* (Keynotes on line, Conn-Selmer Institute, 1999), <http://www.keynotesmagazine.com/article.php?uid=187> (assessed January 10, 2008).

<sup>107</sup> David Heeger, *Linear Systems Theory* (Department of Psychology, New York University, 2003), <http://www.cns.nyu.edu/~david/handouts/linear-systems/linear-systems.htm> (accessed November 22, 2008).

the string is bowed the sound might be good, but more than likely, it can be distorted to a whistle or a grunt. The difference stems from a fundamental distinction between the physics of plucked and bowed strings.<sup>108</sup> Teachers want their students to succeed, and may feel that because there are so many possible outcomes when using the bow, many of which are discouraging, it might be best to postpone its introduction. Unfortunately, this may not be an approach that creates the best outcome for students. Tone-production is a critical element in violin playing, and tone quality can be a primary judgment to differentiate between the accomplished and the unskilled violinist. Beginning students can benefit from learning how a good tone is produced. Postponing the development and understanding of good tone can have a long-lasting effect on their musical growth and enjoyment for playing.

Music notation contains bowing symbols, showing when to use an up-bow, down-bow, slurs, staccato, or marcato, crescendo, and diminuendo bowings. These bowing parameters are well defined. Tone-production is often traditionally taught through modeling and without symbols in the printed music to direct students to add pressure to their bow or move the bow slower or faster, it up to the teacher to explain and

---

<sup>108</sup> Woodhouse, "Why Violin Hard Play?"

demonstrate. For a variety of reasons, teachers with backgrounds other than strings are filling positions that traditionally only string educators held. There is now a need to explore other approaches to teach tone-production that does not necessary need the teacher to model.<sup>109</sup>

In Chapter Six, the synthesis of teaching good tone-production will be discussed. Practice studies relating to this synthesis can be located in the Appendix A: Application. The discussions in Chapter Six are easily adaptable to all string environments, and can be implemented without the teacher demonstrating. When students learn through self-discovery, it can be a powerful experience. And through teacher guidance, rather than demonstration, they can succeed in producing Helmholtz Motion in the signature modes of their instrument and produce the largest amplitudes of the harmonics.

---

<sup>109</sup> Anonymous, "WANTED: 5,000 String Teachers! Status of Orchestra Programs in America's Schools," In *The American Music Teacher*, ed. American String Teachers Association and National School Orchestra Association: The Music Teachers National Association (August 1, 2002): 3, [www.astaweb.com](http://www.astaweb.com) (accessed January 3, 2009).

## CHAPTER SIX

### SUMMARY AND SYNTHESIS

How might tone-production be taught more effectively in the elementary and secondary classroom? Prior to 1970, string classes were traditionally taught by teachers with a professional strings background.<sup>1</sup> Although having a trained string teacher in the classroom does not necessarily guarantee that students will learn good tone-production, this does permit the teacher to model the sound students need to match. Traditionally, good tone-production is reliant on modeling and one to one instruction. For a variety of reasons, music teachers without experience in string performance are assigned to teach strings. As a result modeling good tone-production is not always possible. To keep the focus on student learning, a new method of teaching good tone-production needs to be developed, one that does not require the teacher to demonstrate.

In this chapter, a simple straightforward method for teaching good tone-production in various string settings will be discussed. The ideas for developing this new method are a culmination of published acoustical research, master teachers' tone-

---

<sup>1</sup> Albert Yiu Jeung, "Class Fundamentals for Strings: A Supplementary Method Book for Intermediate String Orchestra in Department of Music," (MA thesis, California State University Long Beach, 1999), 107.

production pedagogy (included in Chapters Four and Five), and the author's experiences as a professional violinist, private violin teacher, public school orchestra director, and conductor.

Certain standard phrases are used in the string class to help students produce a good tone. Unfortunately, some of the commonly used and well-intended phrases can have the opposite effect.

### **Mixed Message Number 1: "Make a Big Beautiful Tone"**

When students are asked to make a "big beautiful tone," they are often being encouraged to produce a 'double-slip' in Helmholtz Motion. Double-slip can result from insufficient bow pressure. If the horsehairs do not catch the string, then it can have an extra slip before it sticks. Helmholtz Motion is created by the friction of the bow, and is produced only with the repetitive motion of the horsehairs sticking and slipping. When this pattern changes, Helmholtz Motion is lost.

As discussed in Chapter Four, Guettler found that string students who are just starting to play actually prefer the sound of 'double-slip motion'.<sup>2</sup> In particular, violin and viola students, because of the close proximity of the instrument to their ear. The primary reason students create the 'double-slip' in Helmholtz Motion is they do not have an adequate amount of pressure on their bow. When the bow pressure "is insufficiently

---

<sup>2</sup> Guettler, "The Bowed String".

high, it is not possible for the string to stick to the bow throughout the nominal sticking period of the Helmholtz Motion.”<sup>3</sup> When the string vibrates in this ‘double-slip motion’, the fundamental frequency does not change, meaning the player can still hear a pitch, however, there is little tone quality.<sup>4</sup> This sound is preferred initially by young players, unless taught to know what a quality tone, rich in overtones, sounds like.

The quality of tone is “determined by the amplitudes of the harmonics which are present”<sup>5</sup> Therefore, asking students to listen for a beautiful tone when they play, will not help them to re-calibrate their ear to play with Helmholtz Motion.

### **Mixed Message Number 2: “Big Bows for a Big Sound”**

Many times teachers will ask students to play with a longer bow stroke to help them play with a loud, strong sound. Yet, a result of asking for more bow can produce the ‘double-slip’ motion, because students do not naturally increase their bow pressure at the same time.

Master teachers and physicists agree that bow speed and bow pressure are correlated. When the horsehairs on the bow do not catch the string to create sufficient friction, the string vibration will not contain Helmholtz Motion. When the fundamental

---

<sup>3</sup> Schumacher, R. T. and Jim Woodhouse, “Computer Modelling of Violin Playing,” *Contemporary Physics* 36, no. 2 (1995): 81.

<sup>4</sup> Schumacher, 82.

<sup>5</sup> Beament, 10.

is not engaged in Helmholtz Motion, the amplitudes of its harmonic upper partials are small, thus creating a “flautando” or “airy” timbre with little or no projection. If the bow force is too great, all resemblance of a musical note can be lost, leading to “raucousness” or “grinding” sounds. If the stick-slip motion is lost, then the string cannot vibrate in Helmholtz Motion.<sup>6</sup>

A big sound can be achieved by playing with the bow at a moderate bow speed, in the center section between the bridge and the fingerboard, with additional pressure. To achieve a big sound when playing in the higher positions, play with a much slower bow speed, closest to the bridge, and less pressure.<sup>7</sup> This will maintain the Helmholtz Motion, and produce the largest amplitudes in the harmonics, thus creating good tone-production.

### **Mixed Message Number 3: Get a Better Quality Instrument to Improve Tone**

There is a notion among many string teachers that when students are not producing a good tone, then purchasing a better quality instrument is the first step towards improvement.<sup>8</sup> Quality of instrument does affect some aspects of tone production; however, Chapter Four presented abundant material to challenge and reframe this assumption. In particular, within the first position range of all violins, the modal

---

<sup>6</sup> Schumacher, 82.

<sup>7</sup> Simon Fischer, *Basics*, 41.

<sup>8</sup> Hamann, 134.

qualities are the same.<sup>9</sup> George Bissinger, physicists at East Carolina University, studies modal qualities of the violin and states, “all violins tested showed the same five ‘Signature Modes’ below 600 Hz, with no obvious quality trends for mode frequencies or total damping.”<sup>10</sup> According to Bissinger, “the only ‘robust’ quality differentiator difference; was the approximately 280 Hz, Helmholtz-type A0 cavity mode.”<sup>11</sup> Therefore, if all violins contain the same modes within the first position register, then all students can produce the Helmholtz Motion. This does not mean that all violins will have the same quality; however, it does mean that no matter what the value, if the string can be engaged in Helmholtz Motion, then the instrument has the capability of reaching its maximum tone quality.

The amplitudes of the harmonics produce what is perceived as the quality of tone. This is not to suggest that all instruments are equivalent, but the core element of tone quality is accessible to all. If students can apply the appropriate friction to the bow, the horsehairs adhere to the string. This engages the Helmholtz Motion in the vibrating string, thereby increasing the amplitudes of the upper harmonic partials. Consequently, the tone will improve without the purchase of an expensive instrument.

---

<sup>9</sup> Marshall, 697.

<sup>10</sup> Bissinger, “Good and Bad Violins,” 1764.

<sup>11</sup> Bissinger, “Good and Bad Violins,” 1764.

## The New Method

There are missing links between acoustical findings and master violin teachers' tone-production pedagogies. By providing the missing thread for these, teachers and students can achieve a better understanding of how to produce good tone on their instrument. Acoustical findings can successfully be correlated into master teachers' pedagogy for tone-production, creating a method that is directive, and focused on student discovery through guided activities — rather than teacher modeling.

Developing a new method for effectively teaching good tone-production might seem difficult, especially in large heterogeneous classes, yet with appropriate sequential steps, this can be surprising easy. This method has a primary focus on the violin and viola; and with minor adaptations can extend to cello and string bass. Additionally this method can be used at different levels of instruction and in ensemble conducting. Students at varying musical levels can have fun with the practice studies (provided in the Appendix A: Application) and yet at the same time learn valuable lessons in physics and acoustics. The string instruments are “highly acoustical,” therefore, learning about Helmholtz Motion, and the Schelleng Diagram will create a connection that is logical for students.<sup>12</sup>

Helping students achieve the Helmholtz Motion is a matter of simple steps, all of

---

<sup>12</sup> Schleske, "Zeitgeist," 1.

which can be presented without modeling. Although modeling is a common and successful method for teaching a good tone, some teachers and conductors may not have a strings background. They will be unable to effectively implement modeling.

### **Applying Physics to Teaching Good Tone-Production**

Acoustical physicists use measurements to determine that the bowed string is vibrating in Helmholtz Motion, creating a quality tone. Master teachers use their ears to determine if the sound they produce includes a robust mixture of harmonics, creating a quality tone. Although each has a different process for determining a quality tone, the end result remains the same. Understanding the vocabulary unique to physicists and master teachers, can provide parallel concepts that teachers can use to enhance student learning. Using this vocabulary during instruction as “trigger words” can provide reinforcement and clarification for students, especially when hands-on-correction is not possible.

There are four components that make-up the new method for teaching good tone: (1) recalibration of the ear, (2) rebalance of components, (3) instructional vocabulary, and (4) exercises and drills.

### **Recalibration of the Ear**

Obtaining the Helmholtz Motion when bowing a string instrument will not produce the sound students correlates with a good tone. Students need to re-calibrate

their ears so they learn what to listen for. Playing tones that include strong harmonics will need more pressure that will result in additional bow friction noise to the person in close proximity to the instrument. When students play with Helmholtz Motion, it can be a challenge on their ears, especially for violin and viola students. This is because of the proximity of their ear to the instrument. Because of this, students usually tend to play soft unless instructed to play into the “wood of their bow.”<sup>13</sup> When students apply the appropriate pressure to the bow and the corresponding speed necessary to engage Helmholtz Motion, they will describe what they hear as squeaks, raucousness, or roughness. This may be the result of two conditions. First, the bow noise caused by friction between the rosin and the string. Second, the increase in the numbers of audible harmonics in the note because of their large amplitudes.<sup>14</sup> As the bow travels down the string in one direction, the horsehairs catch hold of the string. When the string can no longer extend, it quickly releases, before the horsehairs catch it again. Scientists refer to this as the “sticking and slipping motion.”<sup>15</sup> Rosin is applied to the horsehairs help to facilitate this “sticking and slipping motion,” but bow pressure is needed to sustain it.<sup>16</sup>

---

<sup>13</sup> Fischer, “Playing into the Wood,” 66.

<sup>14</sup> Beament, 18.

<sup>15</sup> Woodhouse, “Why Is Violin So Hard?”.

<sup>16</sup> Schumacher, 81.

## **Re-Balance of Components: Pressure, Speed, and Contact Point**

Earlier in this chapter, possible outcomes of commonly used phrases are discussed. Conductors and teachers may instruct students to play with a longer bow stroke, to achieve a loud dynamic; this is true in some circumstances, but not all.

Appendix A: Application includes exercises to re-balance and clarify what combinations of pressure, speed, and contact point produces what outcome. The exercises are based on directed self-discovery that does not exclusively depend on modeling.

## **Instructional Vocabulary**

Teaching good tone-production has an immediate and recognizable effect. A small amount of effective instruction can produce a significant difference in the sound of a player or an ensemble. Instructional vocabulary used during tone exercises and drills can become a tool to help students recover concepts, therefore maintaining momentum in classroom instruction. The vocabulary can generate a visual aid for students, and can result in a faster recollection of specific tone and dynamic changes in the music. Imagery is a powerful teaching tool, and coupling tone-production with familiar vocabulary, can help students retain and recall information quickly.

## **Drills and Exercises**

Mastery of any technique requires repetition. This is also true when learning to produce good tone quality. Appendix A: Application provides a structured and systematic routine of exercise for students to master through directed self-discovery. The drills are structured for easy insertion into heterogeneous classes of elementary, secondary and college level. Conductors without a professional strings background can achieve the same results as ones familiar with tone-production pedagogy.

Providing connecting links between science and art can enhance student achievement and enjoyment for their instrument.

CHAPTER SEVEN  
SUMMARY — CONCLUSION

In Chapter Four the discussion of tone-production begins with the Helmholtz Motion; the simplest behavior of a vibrating string. The Helmholtz corner travels up and down the string; making it appear that the string vibrates as a single loop.<sup>1</sup> This motion is created with friction from the coarse horsehairs, alternately sticking then slipping as the bow is pulled across a string.

All bowed string instruments produce a tone when the bow travels across a string. In order to get the largest amplitudes in the note's harmonic series, the key measurable distinction of a good tone, the string must be engaged in Helmholtz Motion.<sup>2</sup> The correct speed and pressure on the bow will allow the horsehairs to adhere to the string. This engages Helmholtz Motion and increases the amplitudes of the harmonics of the note, thus creating a full rich tone-quality.

Ernest Chladni provides a visual aid of the vibrational patterns in the violin's body. Based on acoustical findings, the first five vibrating modes formed in the cavity

---

<sup>1</sup> Beament, 15.

<sup>2</sup> Beament, 10.

and top-plate of the violin are the same in each instrument, independent of its cost.<sup>3</sup>

These five modes are called Signature Modes.

Another contribution to understanding good tone is the Schelleng Diagram.<sup>4</sup> This is a visual description of changeable sound qualities produced in varying bow pressures and contact-points.

Applying the findings of Helmholtz, Chladni, and Schelleng can help students with their understanding of good tone. It is important for students to realize that good tone will include metallic or friction sound as a result of the horsehairs catching the string to maintain Helmholtz Motion. This is an important part of training the string player: helping them re-calibrate their ears.

Master teachers of recent generations have created an enduring legacy of instructional material and approaches. There are many points of natural connection between scientific findings and pedagogical traditions.

Robert Gerle emphasizes scientific findings in his teaching, saying that although there are many “legitimate and successful approaches to the art of bowing . . . certain mechanical, physical . . . and acoustical rules are constant and beyond dispute.”<sup>5</sup> Master teachers may never say Hermann von Helmholtz or John Schelling’s name in their

---

<sup>3</sup> Marshall, 697.

<sup>4</sup> Schelleng, 72.

<sup>5</sup> Gerle, 15.

private studio, but their message when teaching tone-production is consistent with these scientists.

The importance of the bow has been clearly documented by all the great master violin teachers of the twentieth century. Aaron Rosand states, “bowing is the thing that separates the masters from the rest of the players.”<sup>6</sup> Raphael Bronstein uses imagery to define the importance of the bow in his book, *The Science of Violin Playing*, stating that, “the function of the right hand in playing a stringed instrument might well be compared to that of a painter, and the bow to his brush . . . a great deal of subtlety and phrasing can be created with the bow.”<sup>7</sup> Gerle states that many young musicians do not spend the time needed to acquire the skill, and the concept of bowing, so as to convey musical intentions within the music they are performing, “hoping that mere repetition will miraculously bring out the desired effect.”<sup>8</sup>

When students are able to achieve a quality tone engaged in Helmholtz Motion, they can hear what they are playing, and having more confidence in the right-hand can result in psychological strength for the left-hand. Students enjoy playing more because the feedback they receive from people listening is genuinely positive.

Teachers can implement basic scientific concepts using the practice exercises in Appendix A: Application. Many of these are adapted from master teachers’ tone-

---

<sup>6</sup> Samuel Applebaum and Sada Applebaum, *The Way They Play, Book 3* (Neptune City, NJ: Paganiniana Publications, 1975), 313.

<sup>7</sup> Bronstein, 25.

<sup>8</sup> Gerle, *Art of Bowing*, 15.

production pedagogy; many have been passed along from teacher to students for generations. By adding a slight modern twist, the exercises can successfully develop student's awareness and technique for producing good tone.

### **Proposed Future Research**

Additional research could be done on the human perception of good tone-production on contemporary instruments. A study to address reasons why some musicians still prefer the older Italian violins may provide contemporary makers important opportunities.

The *New Method* presented in this study, could be evaluated using two separate beginning string classes for comparison. The two groups would need to be similar in social-economical backgrounds, and the two teachers would need to have parallel skills and experience.

A study could be done on the effects different types of bow material have on tone-production. Do Pernambuco and Carbon-fiber violin bows produce the same tone on a violin? Sound recordings and blindfold listening tests can be held, and data collected can be interpreted.

A study could be done on the development of published literature with notational details for the young player. Origins of the literature's most popular terms can be determined including "bow lanes" and "bow highways."

The development of teacher training sessions based on the *New Method* presented in this study could present material using a web-based program, specifically for the special circumstances of the American public school string program.

## APPENDIX A: APPLICATION

Why is it important to teach the Helmholtz Motion to beginning string students?

When students know how to engage the string in Helmholtz Motion, they produce a better tone on their instrument. The ability to produce a better tone helps them hear pitches more clearly and gives them confidence. Student learning is enhanced by that confidence. It is more gratifying and fun to play when the sound has depth and richness.

Most string teachers give some attention to building good tone in their strings class, orchestra, or private studio. Many basic ideas are in general circulation among string educators and conductors. This Appendix adapts these existing materials to the scientific and technical insights presented in the body of this study. The resulting systematic approach (The New Method) can be applied to most string settings. Key components of The New Method are presented below and are followed by sample Practice Exercises. These exercises can be used to effectively enhance student learning and accomplishment.

The practice exercises build on established tone-production studies, such as Samuel Applebaum's "Rote Exercises" from Chapter Sixteen in *The Art and Science of*

*String Performance*,<sup>1</sup> and exercises in Fischer's book *Practice*.<sup>2</sup>

Fischer's exercises in *Practice* are an excellent source for teachers. His ideas help students learn how a good tone sounds, and how to play it. Because many of his practice ideas are from his teacher, Dorothy Delay, his book focuses on the advanced level student. Fischer writes a regular monthly column called "Basics" in *The Strad* and his master classes can be found on YouTube. His use of the Internet is an additional opportunity for students and teachers to hear and then reproduce good tone.

The practice exercises included in this Appendix are built upon what this author has been taught, what the author has tested in elementary and high school classes, and what the author has learned through research for this study. Unlike some of previously published materials, these exercises are specific to teaching violin students, but can be adapted for viola, cello, and bass. The exercises can be adapted for all levels of ability. If presented as outlined students can learn to re-calibrate their ears to hear the characteristics of a good tone. It will take students time to be able to remember to play with Helmholtz Motion. Therefore, starting each class with one or two of the following exercises can help students focus on this technique.

The following exercises are structured for teaching the beginning string level in a public school heterogeneous strings class. Each can be easily adapted for middle school

---

<sup>1</sup> Samuel Applebaum and Thomas Lindsay, "Rote Exercises to Develop Specific Skills," Chapter 16 (159-178), in *The Art and Science of String Performance*, (Sherman Oaks, CA: Alfred Publishing, 1986).

<sup>2</sup> Fischer, *Practice*. 47-57.

and high school age levels. The exercises can also be adapted for conductors of full or string orchestras.

### **Introduction and Vocabulary**

Traditional vocabulary (bow pressure, bow speed, and contact point) coupled with modeling and physical correction have been central to master teachers' pedagogies of tone production. Traditionally these have been engaged one student at a time. Therefore, part of this new method of teaching good tone-production is building a broader vocabulary so that students can understand more clearly, and so that corrections within a class or ensemble can be made quickly and effectively.

The following list of vocabulary words are used in the structured practice exercises found in this Appendix. Because every learning environment has its own unique history, teachers are encouraged to adapt this terminology as needed. Terminology that connects students to the concept will encourage self-discovery and ensure that new techniques and concepts are understood.

- Bow first-finger — the pointer finger on the right hand. Refer to lever system.
- Bow push-ups — a silent bow pressure exercise. Place the bow on the string at its middle, using the bow-first finger and bow-thumb as a lever, push down on the stick until it touches the string, then release.

- Bow-thumb — the thumb on the right hand. The thumb is the fulcrum in the bow lever system. Refer to lever system.
- Lever system — “the thumb on the bow-hand is the fulcrum; the small/pinkie finger is the effort; and the length of the bow is the load. The crucial forefinger is used to shift the "load" laterally, as well as to somewhat counterbalance the force of the pinkie ("effort").”<sup>3</sup>
- Metallic — a perceived quality of tone produced when the string is vibrating in Helmholtz Motion (also referred to as raucousness, throaty, or raspy sound).
- Professional sound — a trigger word reminding students to have their string vibrate in Helmholtz Motion.
- Push the stick to the hair — applying pressure to the bow using a lever action. Refer to lever system.
- Springiness part of the bow — the middle of the bow, where is horsehair is closest to the stick.

---

<sup>3</sup> Timothy James Dimacali, “Bow Hold: Concerned with Finding a Better Bow Hold and Improving Flexibility...,” Violinist.com Discussion Posting, September 3, 2007, <http://www.violinist.com/discussion/response.cfm?ID=12056> (accessed February 13, 2009).

- Ripple effect — for every action (or force) there is a reaction (or opposing force) of equal strength but opposite direction; Newton’s third law of motion.<sup>4</sup>

### **Introducing the Helmholtz Motion**

Teaching the essential element of a vibrating string, Helmholtz Motion, can help students focus on their bow. Having students watch the string vibrate when they play may seem inconsequential, but this is an important first step for teaching good tone. When the string is vibrating widely in Helmholtz Motion, the tone produced is good. Students may not correlate this sound with being a good tone, so remind them that what they hear under their ear is not what the audience hears. When their sound is perceived as metallic, it will project to the back of the concert hall and sound “beautiful” to those listening.

### **Practice Exercise I: Learning to Play with Helmholtz Motion**

1. Have students play their open D-string, and ask them to watch their string vibrate.
2. Ask them to make their open D-string vibrate as wide as possible.

---

<sup>4</sup> Newton's Third Law of Motion, <http://www.bbc.co.uk/dna/h2g2/A121041> (accessed February 13, 2009).

3. Ask them to describe what the vibrating string looks like.  
 Answers may be: (1) wiggling, (2) moving back and forth, or (3) moving to one side.
  
4. Ask them if they have heard of the scientist Hermann von Helmholtz. Tell them about the experiment he did with a black string fastened to a tuning fork that was marked with one white dot. When he watched the string vibrate, he saw that it vibrated very differently from what is seen with the naked eye.
  
5. Draw figure A.01 on the board, showing what they see, and what Helmholtz saw in the dark room.

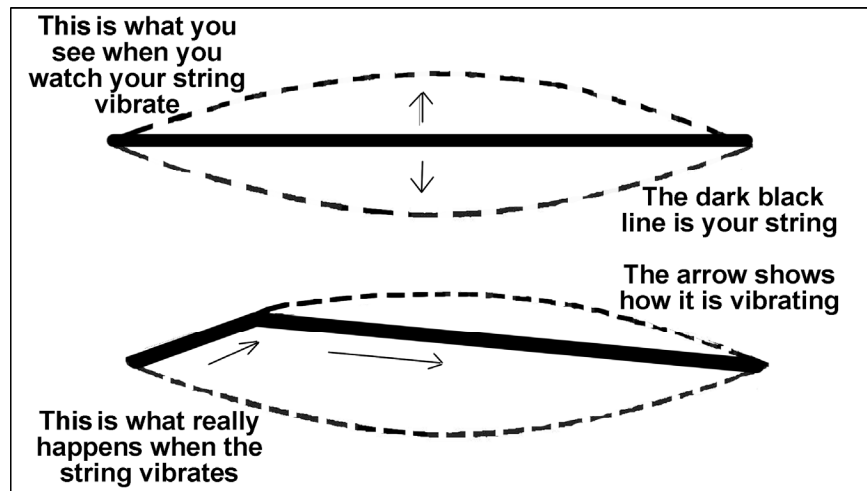

**Figure A.01: Blackboard Drawing of the Helmholtz Motion**

6. Have students play their open D-string again, and ask them to make the string vibrate very widely in Helmholtz Motion. Suggest they put more pressure on the string using their bow-thumb and bow-first finger like a lever. Suggest that they slow their bow-speed. Ask if their bow is traveling straight and parallel to the bridge. Ask them to bow closer to the bridge, especially if

students play on mass-produced instruments with a poorly set bridge. Students may play soft to keep from playing more than one string at a time. Having them bow closer to the bridge allows them to “play into the wood of the bow,” and play on one string at a time.<sup>5</sup>

7. Ask students what their string sounds like when they play with Helmholtz Motion.

Answers may be: (1) screechy (2) throaty (3) raspy.

Helmholtz referred to this sound as “metallic.”<sup>6</sup>

8. Remind students that the sound they hear under their ear is not what the audience will hear. The slightly metallic sound (Helmholtz Motion) coming from their violin will sound beautiful to the audience.
9. Tell students that this is what a good tone sounds like. Helmholtz Motion is created by friction and the notes produced contain large harmonic upper partials — this is how the professional string players sound.

Use the term, “professional” sound when students are playing throughout the class. This trigger word can help them remember to bow so their strings vibrate as widely as possible.

---

<sup>5</sup> Fischer, “Playing into the Wood,” 66.

<sup>6</sup> Helmholtz, 71.

## **Bow Pressure**

The starting point for teaching tone-production is bow pressure. As discussed earlier, the word ‘pressure’ is not considered positive by most string educators. However, the common practice of asking students to apply “weight” to their bow can lead to more confusion than understanding.<sup>7</sup> The term pressure is clear for students. Because this component of teaching tone-production is habitually ignored, responsibly adjusting to the word pressure can be good. Concise and clear terminology is important.

### **Practice Exercise II: Silent Push-Ups**

1. Ask students to make a lever out of their bow using their bow-thumb and their bow-first finger.<sup>8</sup>
2. Have students put their bow on the D-string, placing it on the string at the middle-area, or “springiness” section of the bow.<sup>9</sup>
3. Have students make ‘silent push-ups,’ only using their bow-thumb and bow-first finger. Their bow becomes a lever.<sup>10</sup>
4. Ask students to feel the tension and resistance of the bow’s stick when it touches the horsehairs.

---

<sup>7</sup> Fischer, “Tone Production,” (2008): 77.

<sup>8</sup> Gerle, 45.

<sup>9</sup> Fischer, “Playing into the Wood,” 66.

<sup>10</sup> Galamian, 55.

Master teachers Galamian, Gerle, and Fischer include a reference to using the bow as a lever in their pedagogies. This visual aid can help students focus on using the fingers of their right hand to apply pressure to the bow, as apposed to their arm or shoulder.

Remind students that it does not take a lot of ‘muscle’ to make the ‘stick touch the hair’, only their bow-thumb and bow-first finger are needed.

### **Practice Exercise III: Move the String Without Making a Sound.**

1. Ask students to touch the stick of their bow to the horsehair on their string. There should be no sound and no bow movement.
2. While keeping ‘pressure’ on their bow, ask students to move the string back and forth, without making any sound. There may be a few bow slips at first, causing a ‘rug-burn’ or ‘creak’ sound.
3. Remind students to keep the bow on the string with pressure so that the string rocks back and forth underneath the weight.<sup>11</sup>

### **Re-Calibrating the Ear**

When students are first learning how to play with an overtone-rich tone engaged in Helmholtz Motion it could be a challenge to their ears. Therefore, introducing the new

---

<sup>11</sup> Applebaum, “Rote Exercises,” 169.

idea of what a quality tone really is might be puzzling. A lot of reminding will be necessary for the action to become automatic. The following exercises and procedures can be useful to help re-calibrate student's ears to what to listen for in making a good tone on their string instrument.

To help students become accustomed to hearing this new sound, it is important to “desensitize” students to the noise caused by bow friction. The following practice study is one of the best ways to help desensitize students to the friction between the bow and the string and to begin the process of knowing what a good tone is supposed to sound like.

#### **Practice Exercise IV: Desensitizing the Ear**

1. Have students drag their bow slowly across the D-string, making the stick of the bow touch the horsehair.
2. Apply this combination of a slow bow with excessive bow pressure to a one-octave D major scale. Call it the “Ugly Scale.”<sup>12</sup>

Desensitizing students to the sound produced when they bow with excessive pressure will help them re-calibrate their ear to knowing what a good tone is. This exercise can help

---

<sup>12</sup> James Gardner, violinist and Music Department Chair (George Mason University, Fairfax, VA, 2008).

desensitize student's ears to the bow friction they hear under their ear, and part of the 'metallic' sound in Helmholtz Motion.<sup>13</sup> Exaggerating the amount of pressure placed on the bow, and asking students to maintain this sound as their bow moves across the string, will help them to isolate a very important ingredient need for tone-production; friction. Friction is the result of bow pressure and friction is needed to obtain the Helmholtz Motion.

### **Bow Speed**

The next step in the sequence of teaching tone-production is for students to learn how bow speed influences good tone-production. A higher bow speed will generally produce a louder tone, and will affect the amount of pressure that should be applied to the string for a tone with a strong fundamental. If too little bow pressure is applied to the string, multiple slips will occur per waveform period. This can even produce a note an octave higher, (a squeak) or other significant changes in tone.<sup>14</sup>

An excellent exercise for teaching good tone-production using bow speed in a heterogeneous group begins with counting out-loud with a steady beat (metronome: sixty beats per minute) while playing an open string.

---

<sup>13</sup> Helmholtz, 71.

<sup>14</sup> Fletcher, *Physics of Musical Instruments*, 314.

## **Practice Exercise V: Counting Aloud with a Steady Beat**

The bow must be placed at its frog to start, and when a number ten reached, the bow should be at its tip. Be sure students know before they play how many beats per bow you want them to play and be sure the instructions of how many beats for the next bow are given quickly so students do not have too much time to analyze. Remind students to watch their string to make sure it is vibrating as widely as possible.

1. Ask students to play one down-bow lasting ten beats, trying to make the string vibrate widely.<sup>15</sup>
2. Then reverse the exercise by starting at the tip of the bow. Ask students to play one up-bow lasting ten beats, trying to make the string vibrate widely.

Within a small amount of time, students will begin to better judge what speed their bow needs to travel in order for them to be at the opposite end of the bow with in a particular number of beats while maintaining a wide string vibration. Keep reminding them to move the bow at a consistent speed so that they reach the end of their bow exactly on the last spoken number. Once the majority of students have mastered this, vary the number of beats going up and down, and then slowly decrease the number of beats to only one count (beat) down-bow and one count (beat) up-bow.

---

<sup>15</sup> Metronome marking set at sixty beats per second. Count and beat are interchangeable in the exercises.

1. Ask students to play one down-bow and one up-bow lasting nine beats, trying to make the string vibrate widely.
2. Ask students to play one down-bow and one up-bow lasting two beats, trying to make the string vibrate widely.
3. Ask students to play one down-bow and one up-bow lasting one beat, trying to make the string vibrate widely.

Mixing it up is fun for students. For example, have them play up-bow ten beats, and down-bow on one beat.

#### **Practice Exercise VI: How High Can We Count?**

1. Have students to play a down-bow very slowly while the teacher counts aloud up to twenty.
2. Repeat the exercise, going five to ten numbers higher. Remind students to keep their bow moving throughout the entire exercise.

Learning bow speed can begin early in a string player's development. Having students learn how to make their bow move slowly between the frog and the tip (minimal bow speed) can help them achieve more bow control when slurs are introduced.

### **Practice Exercise VII: Varying Bow Speeds (Advanced)**

Have students play three open D quarter notes in the following manner:

1. Begin the first quarter note at the frog of the bow then travel three-quarters of the length of the bow towards the tip without accents.
2. The second quarter note begins where the bow had previously stopped then travels one-third the length of the bow toward the frog without accents.
3. The last quarter note begins where the bow had stopped then travels toward the tip of the bow. It should begin at three-quarters of the length of the bow and move toward the tip without accents.<sup>16</sup>

### **Practice Exercise VIII: Different Length Notes — Playing with Whole Bows**

1. Ask students to play a D major scale  $\frac{3}{4}$  time signature, the first note a half note, the second note a quarter note.
2. Use the same amount of bow for each down and each up-bow.

Students will hear that the quarter note sounds louder than the half note. Now ask the students to use less bow pressure on the quarter note, so that it matches the dynamic level

---

<sup>16</sup> Fischer, *Basics*, 51.

of the half note. They should strive for a “completely even sound and even volume” when they play.<sup>17</sup>

Scales can be another way of implement this bow speed exercise and this can become part of daily warm-up exercises.

### **Practice Exercise IX: Variations in Bow Speed Using Slurs**

1. Have students play a D major scale with three notes slurred together and one note separate.
2. Begin with the students the same amount of bow for the three slurred notes and the one single note.

Students will recognize that the one note they play separate from the other three is much louder. Now ask the students to release the bow pressure on the single note so that it matches the dynamic level of the three slurred notes. They should strive for a “completely even sound and even volume” when they play.<sup>18</sup>

By having the students concentrate on just the speed of their bow, they will see clearly that the sound produced by their instrument changes depending on their bow speed. By starting students with long slow bows at the beginning of this exercise, they

---

<sup>17</sup> Fischer, *Basics*, 53.

<sup>18</sup> Fischer, *Basics*, 53.

will begin to learn how friction varies with speed and results in different shadings of tone.

### **Contact Point Pedagogy**

Students who have mastered the proceeding drills are now familiar with how much bow pressure needs to be applied to create the proper amount of friction, and they understand how bow speed influences the overall sound from the instrument. There is an additional bow technique that needs to be taught. This will give students the ability to produce the widest range of dynamics and tone color, while the string is vibrating in Helmholtz Motion.

It is useful to divide the area between the bridge and the fingerboard into five lanes or contact points. Playing on each of the five contact points can create a different character of tone. These can be numbered one to five, beginning at the bridge and moving toward the fingerboard. The more students are able to hear these unique characteristics in their sound the better prepared they will be to apply this technique while playing. Being able to isolate and perfect each contact point is not initially necessary. It is important for students to hear and understand the differences between playing at the two extreme contact points (i.e. playing on contact point one apposed to playing on contact point five). Figure A.02, is a diagram of the contact points that can be drawn on the board for students.

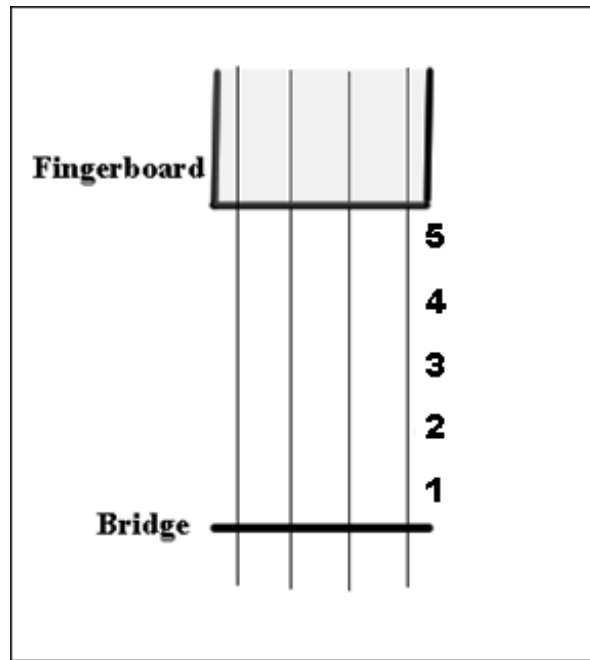

**Figure A.02: Simple Model of Contact Points**

When the bow is near the fingerboard the Helmholtz corner (kink, refer to figure 4.04) is more rounded resulting in greater sonority. The notes do not include many higher harmonics.<sup>19</sup> When the bow is closer to the bridge, the Helmholtz kink is sharper, and the sound has more edge to it. The notes have more of the higher harmonics.<sup>20</sup> This is the scientific reason why master teachers use contact point pedagogy to obtain the widest variation in dynamics.

---

<sup>19</sup> John McLennan, *The Art, History, and Science of Violin Making* (lecture, University of Newcastle, Australia, August 1993), 5.

<sup>20</sup> McLennan, 5.

### **Practice Exercise X: Tour of Contact Point 5 and 1**

1. Ask students to maintain the same bow pressure and the same bow speed while they are playing this exercise.
2. Have students play open D-string, placing their bow on contact point 5.
3. Provide a visual aid, write figure A.02 on the board.
4. Ask students to watch and be sure their bow remains on contact point 5 the entire time they play their open string for four beats.
5. Repeat this exact exercise with the bow on contact point 1 closest to the bridge.

Students can hear the difference in these two contact points. By having students play only using the two outer areas (contact point 1, and contact point 5) they will hear two very opposite and distinct tone qualities.

As you repeat this practice exercise remind students to keep the same bow pressure and bow speed but sustain the open D-string note for only three beats on contact point 5, and then again on contact point 1. Repeat the exercise again with two beats and then finally with one beat, reminding students each time to keep the same bow pressure and bow speed and to watch that their bow remains on the correct contact point.

### **Practice Exercise XI: Rhythms on Each Contact Point (Advanced)**

1. Ask students to play a simple rhythm on contact point 5, maintain a constant pressure and bow speed. Have them experiment with speed and pressure until they find the combination that produces the widest vibration in their string.
2. Play this rhythm fast next to the bridge and slow next to the fingerboard.
3. Once the speed and pressure on the bow are correct on contact point 5, play the same rhythm on contact point 4. Again experiment with changing the speed and pressure of the bow until the widest vibration in the string is produced.
4. Play this rhythm fast next to the bridge and slow next to the fingerboard.
5. Repeat this exercise on all the remaining contact points, 3, 2 and 1. Then work backwards starting at contact point 1. Every time play the rhythm fast next to the bridge and slow next to the fingerboard.<sup>21</sup>

These exercises are easy to implement at all levels and take very little time during a class period or an orchestra rehearsal. Because this method is built on student-focused discovery learning, rather than through modeling there can be better retention.

---

<sup>21</sup> Fischer, *Basics*, 46.

A powerful teaching tool when introducing a new bow technique is to exaggerate and isolate the motion. Fischer describes this technique when learning the contact point pedagogy stating that teaching the opposite contact point gives students the best chance to hear the difference.<sup>22</sup>

### **Contact Point Imagery**

Imagery is a powerful tool educators can use to help students understand new concepts. Educators have also learned that students retain new concepts better if they are linked to something with which the student is already familiar. Phyllis Young opens Chapter Four in *Playing the String Game* with the following: “almost every physical action required in string playing, when isolated from all others, is similar to one that has been experienced by the student sometime or somewhere else in everyday life.”<sup>23</sup> Using this simple strategy when teaching tone-production will make the techniques of tone-production seem quite easy for students and will help them retain this knowledge and skill. Teachers will have more success because the reminder clues are simple, easily recognized by the student, and flexible for a variety of settings.

In the traditional master teacher’s studio, tone-production is taught through modeling. Master teachers guide students into playing Helmholtz Motion with the bow,

---

<sup>22</sup> Fischer, “Soundpoint Exercises,” 404.

<sup>23</sup> Phyllis Young, *The String Play: The Drama of Playing and Teaching Strings*, (Austin, TX: University of Texas Press, 1986), 8.

but they do not include the term Helmholtz Motion in their vocabulary for teaching tone. It is important for contemporary teachers and conductors to develop a vocabulary to help direct students towards obtaining sensitivity to tone, and skills in executing a variety of tone colors.

<b>Vocabulary For Describing Contact Points</b>				
<b>Contact Point I</b>	<b>Contact Point II</b>	<b>Contact Point III</b>	<b>Contact Point IV</b>	<b>Contact Point V</b>
<b>Close to the Bridge</b>	<b>Between the Central Point and the Bridge</b>	<b>Central Point</b>	<b>Between the Central Point and the Fingerboard</b>	<b>Close to the Fingerboard</b>
<b>Raucousness Rug-burn Guttural Grittiness Raking Scraping Grinding Creakiness Roughness</b>	<b>Resolute Vigorous Driving Energetic Forceful Heavy</b>	<b>Resonant Warm Sonorous Reverberating Echoing</b>	<b>Dulcet Mellifluous Muted Restrained Honeyed</b>	<b>Ghostly Transparent Translucent Lucid Whistling Ethereal Airy Diaphanous</b>

**Figure A.03: Contact Point Imagery: Maintaining Constant Pressure and Speed**

In figure A.03, each contact point has a list of possible vocabulary words that can be used to create imagery for fast recognition and execution of the proper contact point. Please note that a constant bow pressure and bow speed needs to be maintained for the best outcome.

These “trigger” words that can be used during a rehearsal or class to describe visual textures for each contact point. Students are also encouraged to come up with additional trigger words; however, using one word for each contact point is really best. Using the same words over and over when refer to a specific technique aids the students to respond quickly.

### **Practice Exercise XII: Adding Imagery**

Once students are familiar with the three ingredients that are needed to produce a quality of tone, ask them what characteristics they hear in their tone when playing at the opposite contact point.

1. Ask students to play on “contact point one” for eight beats. Count aloud at a steady beat while students play.
2. Ask students to play on contact point five for eight beats.

On contact point one; the tone can be described as ‘rug-burn’, ‘metallic’, or a scraping, grinding and grittiness in the sound.<sup>24</sup> Whereas, on contact point five the tone can be

---

<sup>24</sup> ‘Rug-burn’ and ‘Metallic’ are used by this author when teaching contact point one and bow friction to create Helmholtz Motion.

described as ‘ghostly’, ‘flute-like’, or transparent.<sup>25</sup> By combining a visual aid to the contact point and adding vocabulary to connect with the sound that each are produces, students can successfully learn tone-production and retain this knowledge so they can apply it when playing, with only the minimum amount of help.

### **Additional Exercises**

#### **Practice Exercise XIII: Feel the Resistance**

A bow exercise for students to feel friction between the bow and the string is to apply opposite motion to the student’s bow while they are playing.<sup>26</sup> This will slow the bow as it travels up and down the string and will help show how the horsehair catches on the string when there is pressure from the bow. This practice study will also teach an important ingredient of tone — friction — which is needed to engage the string in Helmholtz Motion.

1. While a student is sitting in a chair, hold on the stick of their bow with both hands.
2. Ask the student to play a long bow on open A-string.

---

<sup>25</sup> ‘Ghostly’ and ‘flute-like’ are used by this author when teaching contact point five.

<sup>26</sup> Aaron Rosand, Master Class, Reston, VA. Summer 1970.

3. As the bow travels on the down-bow, gently pull the bow towards the tip.
4. As the bow travels on the up-bow, gently push the bow towards the frog.

The opposite pressure you apply can be subtle or more exaggerated, depending on the ability of the student to pick-up on the “feeling” of the subtle resistance between the horsehair and the vibrating string. Interestingly, if a student is having trouble with tone, especially if they are only producing a small thin sound, then if you hold the bow without letting it move down, once you release your hold the student’s bow, the sound will explode from their instrument as the bow races towards the tip. This is always a surprise to the student.

Once students hear the sound created by the Helmholtz Motion and learn how much pressure and speed (friction and resistance) is required, then it is not difficult for them to recreate this sound in normal circumstances.

#### **Practice Exercise XIV: The Anomaly of Strings Vibrating**

Teaching students to watch for sympathetic string vibrations traditional is used as an intonation tool, however, this it can also be a useful tool in developing good tone.<sup>27</sup>

---

<sup>27</sup> Fischer, “Intonation,” *The Strad* 116, no. 1387 (2005): 102.

The first partial tone [or second harmonic] is the upper octave of the prime tone formed by a vibrating string, and the second partial tone [or third harmonic] is the fifth of this octave. When students apply enough pressure to create Helmholtz Motion, these two partial tones can be heard. For example, when students play the first-finger A on the G-string, the open A-string will vibrate. If the first-finger A on the G-string is in tune with the violin's open A-string, the open A-string will vibrate at its widest. When the string is also engaged in Helmholtz Motion, the second partial tone also vibrates; the open E-string.

The following exercise creates an image of the sound waves for students, and can help them hear the first partial tone, which produces sympathetic vibrations at the octave.

1. Ask students if they have seen the rings form in the water around the pebble that they threw in to a lake.
2. Draw a pebble with rings around it on the blackboard.<sup>28</sup>
3. Have students bow the first-finger A on the G-string.
4. Ask students to see if they can make their open A-string vibrate, just by playing first-finger A on the G-string.
5. Remind them to play with a "slight metallic" sound so they know their string is vibrating in Helmholtz Motion.

---

<sup>28</sup> Newton's Laws of Motion, <http://www.bbc.co.uk/dna/h2g2/A121041> .

6. When they see the A-string vibrating, remind them to make the vibrations as wide as possible, by adjusting the first-finger A on the G-string.
7. Once the A-string is vibrating at its widest, have them lift their bow off the string, and listen for the open A ringing.

The second partial (third harmonic) is a fifth above the octave. Violin players should be able to see their open A-string and their open E-string vibrate while playing first-finger A on the G-string. Exercise XV can be taken one-step further; ask if any students can also see their E-string vibrating.

The process of learning to make the open A-string and open E-string vibrate widely by adjusting the first-finger on the G-string, although many times used as an intonation exercise, will help students focus on their string to make sure it is vibrating fully. This exercise teaches students to engage Helmholtz Motion while bowing, and gives them a visual tool to check left hand finger placement, thus helping with intonation.

Sympathetic vibrations will only occur if the fingered note (fundamental) is engaged with the Helmholtz Motion, otherwise there is not enough string vibration generated with the bow to excite the lowest harmonic upper partials (the octave and the fifth) to create the sympathetic string vibrations. When strings do not vibrate enough to produce sympathetic vibrations, there are only a few possible reasons:

1. The fingered note does not match the pitch of the octave open string.

2. Helmholtz Motion has not formed because of the lack of bow pressure or bow speed.
3. The instrument has not been tuned properly — if the open A or open E string is out of tune, one might vibrate but not the other.

Sympathetic string vibrations are also created at the lower octave. For example, if the third-finger D on the A-string is played with Helmholtz Motion; the open D-string will vibrate. The open D-string may not be heard because it is below the sounding note, but its vibration can be seen by the player. The open D-string will vibrate its widest when the third-finger D is absolutely in-tune with the open D-string.

Teaching sympathetic string vibrations can be applied to all string instruments. For example, cello students can play first-finger D on the C-string, the open D-string will vibrate, and the fifth above, and the open A-string can be heard when the bow is lifted off the string.

### **Applying Contact Point Pedagogy**

Using the contact point number system, suggested by Simon Fischer, when conducting, will allow you to hold up the finger number that corresponds with the type of timbre the composer wants.<sup>29</sup> In rehearsal situations, using the appropriate contact point

---

<sup>29</sup> Fischer, *Practice*, 47.

vocabulary, plus saying the contact point number, connects the students to a concept they can remember. Students will have a constant reference if they write in the contact point number in their music. During a concert, the conductor can give students a little reminder by holding up the finger number that corresponds to the appropriate contact point placement. The student's response to the number method needs to be practiced at all rehearsals, so there is no guessing which contact point the bow should be on. This will allow for the performance to be rich with varying dynamics.

Non-string players who teach strings can easily succeed in teaching good tone production, because there is an immediate recognition to the texture variations when students are asked to exaggerate using the outside contact points. This minimizes the need for modeling. Teachers can add these exercises to any level and in any setting, and they enable students to achieve a higher level of satisfaction from their own performances.

## APPENDIX B: USEFUL WEBSITES

### Acoustical Groups

1. Cambridge University — Dynamics & Vibration Research Group:  
<http://www-mech.eng.cam.ac.uk/dynvib/>
2. The Stanford University — Center for Computer Research in Music and Acoustics:  
[:http://ccrma.stanford.edu/](http://ccrma.stanford.edu/)
3. The University of New Southern Wales — School of Physics:  
: <http://www.phys.unsw.edu.au/music/>
4. The University of New Southern Wales — Animated Helmholtz Motion:  
<http://www.phys.unsw.edu.au/jw/Bows.html>
5. KTH: Royal Institute of Technology — Speech, Music and Hearing — Music Acoustics group:  
<http://www.speech.kth.se/staff/musicacoustics.html>
6. East Carolina University — Physic Department: Dr. George Bissinger:  
<http://www.ecu.edu/cs-cas/physics/Acoustics-and-Bioacoustics.cfm>

### Violinmakers

1. Martin Schleske:  
<http://www.schleske.de/en/master-luthier.html>
2. Hans Jóhannsson:  
<http://www.centrum.is/hansi/>

3. Joseph Curtin:  
<http://www.josephcurtinstudios.com/>
4. Gregg T. Alf:  
<http://www.alfstudios.com/>
5. David T. van Zandt:  
<http://www.vanzandtvilins.com/dvz-resources.htm>
6. Alan Coggins & Adèle Beardsmore:  
<http://www.abcviolins.com/>

### **Societies**

1. Catgut Acoustical Society:  
<http://www.catgutacoustical.org/index.htm>
2. The Violin Society of America:  
<http://www.vsa.to/>
3. Acoustical Society of America:  
<http://asa.aip.org/>

### **Simon Fischer Master Classes on YouTube**

1. Australian Strings Association Sound Point Exercise:  
<http://www.youtube.com/watch?v=urFPFn7s3m4&feature=related>
2. Australian Strings Association Tone Workshop 1:  
<http://www.youtube.com/watch?v=u5ZrdfLMQzw&feature=related>
3. Australian Strings Association Tone Workshop 2:  
<http://www.youtube.com/watch?v=JxUPXw7vPJs&feature=related>

4. Australian Strings Association Tone Workshop 3:  
<http://www.youtube.com/watch?v=hjh8biAajB4&feature=related>
5. Australian Strings Association Tone Workshop 4:  
<http://www.youtube.com/watch?v=hL19ds8wbMQ&feature=channel>
6. Australian Strings Association Tone Workshop 5:  
<http://www.youtube.com/watch?v=QEsV8Bsygyo&feature=channel>
7. Australian Strings Association Tone Workshop 6:  
[http://www.youtube.com/watch?v=BdXeH6F\\_iG4&feature=channel](http://www.youtube.com/watch?v=BdXeH6F_iG4&feature=channel)
8. Australian Strings Association Tone Workshop 7:  
<http://www.youtube.com/watch?v=6i05e-cu9fw&feature=channel>

## SELECTED BIBLIOGRAPHY

## SELECTED BIBLIOGRAPHY

- Allen, Michael, Robert Gillespie, and Pamela Tellejohn Hayes. *Essential Elements 2000 for Strings: A Comprehensive String Method, Book One*. Milwaukee, MN: Hal Leonard, 2002.
- Anonymous. "WANTED: 5,000 String Teachers! Status of Orchestra Programs in America's Schools." *The American Music Teacher*. edited by American String Teachers Association and National School Orchestra Association: The Music Teachers National Association (2002). <http://www.astaweb.com> .
- Applebaum, Samuel and Thomas Lindsay. "Rote Exercises to Develop Specific Skills." 159-178 in *The Art and Science of String Performance*. Sherman Oaks, CA: Alfred Publishing, 1986.
- Archambault, Jared, Zachary Jones, and Scott van Note. "Acoustic Visualization & Modeling: Original Chladni Plates." *VizProto* (Spring 2005). <http://www.newalexandria.org/.../teamViz-cymatics.html> .
- Askenfelt, Anders. "A Look at Violin Bows." *Department for Speech, Music and Hearing Quarterly Progress and Status Report* 34 (February/March 1993): 41-48. <http://www.speech.kth.se/qpsr> .
- \_\_\_\_\_. "Measurement of the Bowing Parameters in Violin Playing." *The Journal of the Acoustical Society of America*, 84 (January 1988): 1-30. <http://www.speech.kth.se/qpsr> .
- \_\_\_\_\_. "Measurement of the Bowing Parameters in Violin Playing. II: Bow-Bridge Distance, Dynamic Range, and Limits of Bow Force." *The Journal of the Acoustical Society of America* 86, no 2 (February 1989): 503-516. <http://www.speech.kth.se/publications/> .
- \_\_\_\_\_. "Observations on the Violin Bow and the Interaction with the String." 23-42 in *Music and Hearing Quarterly Progress and Status Report* 36. Stockholm: Royal Institute of Technology (KTH), 1995. <http://www.speech.kth.se/publications/> .

- Beament, James. "The Vibration of Strings" Chapter 2 in *The Violin Explained: Components, Mechanism and Sound*. England: Oxford University Press, 2000.
- Bissinger, George. "Structural Acoustics of Good and Bad Violins. *The Journal of the Acoustical Society of America* 124 (September 2008): 1764- 1773.
- Bissinger, George and David Oliver. "3-D Laser Vibrometry on Legendary Old Italian Violins." *Sound and Vibration* (July 2007): 10-15. <http://www.acoustics.org/press/153rd/bissinger.html>.
- Bossy, Emmanuel and Renaud Carpentier. *First Seven Modes of the Top and Back Plates of a Hand Made Violin*. Physics Department, University of Southern Wales, Australia. <http://www.phys.unsw.edu.au/jw/patterns1.html> .
- \_\_\_\_\_. *First Seven Modes of the Top and Back Plates of a "Lark" Violin*. Physics Department, University of Southern Wales, Australia. <http://www.phys.unsw.edu.au/jw/patterns1.html> .
- Brenner, Brenda. "Setting up for Success in the String Classroom." in *Midwest Band and Orchestra Clinic*. Chicago, IL: Indiana University, Jacobs School of Music, (December 2007).
- Bronstein, Raphael. *The Science of Violin Playing*. Neptune City, NJ: Paganiniana Publications, 1977.
- Brown, Andrew W. and Matthias Bertsch. *The Paradox of Musical Acoustics: Objectifying the Essentially Subjective*. University of Music and Performing Arts Vienna, Austria, 2004. [http://iwk.mdw.ac.at/Forschung/pdf\\_dateien/2004e\\_Brown\\_CIM04.pdf](http://iwk.mdw.ac.at/Forschung/pdf_dateien/2004e_Brown_CIM04.pdf) .
- Buen, Anders. "A Brief Introduction into the Violin Acoustics History." in *The Joint Baltic-Nordic Acoustics Meeting*. Gothenburg, Sweden, 2006.
- \_\_\_\_\_. *Comparing the Sound of Golden Age and Modern Violins: Long-Time-Average Spectra*. Oslo, Norway, 2005.
- \_\_\_\_\_. *Two Models for Predicting the Violin Timbre from the Material Properties of the Top and Back Plates*. Norway: Brekke and Strand Acoustical Association, 2005.

- Chladni, Ernst. *Entdeckungen Über Die Theorie Des Klanges. [Discoveries Concerning the Theory of Sound]* Leipzig, Germany: Breitkopf und Härtel, 1827.
- Coggins, Alan. "Blind Faith." *The Strad* 118, no. 1402 (February 2007): 52-55.
- Cohen, Mary. *Superstart Violin Level I: Basic Skills and Pieces for Beginners*. London: Faber Music, 1997.
- Courtial, Johannes, and Kevin O'Holleran. "Experiments with Twisted Light: Some of the Mechanical and Quantum-Mechanical Properties of Optical Vortices." *European Physical Journal Special Topics* 145 (June 2007): 35-47. <http://www.physics.gla.ac.uk/Optics/papers/authorPDFs/Courtial-OHolleran-2007.pdf>.
- Cremer, Lothar. *The Physics of the Violin*. Translated by John S. Allen. Cambridge, MA: M.I.T. Press, 1984.
- Curtin, Joseph. "Bridging the Divide." *The Strad* 116, no. 1384 (August 2005): 44-48.
- Dabczynski, Andrew, Richard Meyer, Bob Phillips. *String Explorer Teacher Manual, Book I*. Van Nuys, CA: Alfred Publishing, 2002.
- Day, Linda. "Analyzing the Tribiology of Sound." *Tribology & Lubrication Technology* 1 (January 2007): 28-39. [http://www2.eng.cam.ac.uk/~jw12/JW%20PDFs/feature\\_1-07.pdf](http://www2.eng.cam.ac.uk/~jw12/JW%20PDFs/feature_1-07.pdf).
- Dillon-Krass, Jacquelyn. "String Class Teaching Philosophy." *Keynotes Magazine on Line*, Conn-Selmer, (1999). <http://www.keynotesmagazine.com/article.php?uid=187>.
- Dillon, Jacquelyn, James Kjelland, and John O'Reilly. *Strictly Strings: A Comprehensive String Method, Book I, Teacher's Manual*. Van Nuys, CA: Highland/Etling, 1992.
- Dimacali, Timothy James. "Bow Hold: Concerned with Finding a Better Bow Hold and Improving Flexibility..." *Violinist.com Discussion Bow Hold Blog*. (September 2007). <http://www.violinist.com/discussion/response.cfm?ID=12056> (accessed February 13, 2009).
- Dünnwald, Heinrich. "Deduction of Objective Quality Parameters on Old and New Violins." *Catgut Acoustical Society Journal* 1, no. 7 (July 1991): 1-5.

Erwin, Joanne, Kathleen Horvath, Robert McCashin, and Brenda Mitchell. *New Directions for Strings: A Comprehensive String Method Teacher's Manual Book I.*, edited by Brian Balmages. Fort Lauderdale: The FJH Music Co., 2007.

Fischbach, Gerald. "The Appliance of Science." *The Strad* 115, no. 1373 (September 2004): 940-945.

Fischer, Simon. *Basics: 300 Exercises and Practice Routines for the Violin*, edited by Hinrichsen. London: Peters Edition, 1997.

\_\_\_\_\_. "Background Resonance." *The Strad* 118, no. 1406 (June 2007): 77.

\_\_\_\_\_. "Bow Hold." *The Strad* 116, no. 1388 (December 2005): 78-79.

\_\_\_\_\_. "Bow Pressure." *The Strad* 116, no. 1378 (February 2005): 72-73.

\_\_\_\_\_. "Tone Production." *The Strad* 108, no. 1287 (July 1997): 764.

\_\_\_\_\_. "Bow Tilt." *The Strad* 104, no. 1234 (February 1993): 116.

\_\_\_\_\_. "Intonation." *The Strad* 116, no. 1387 (November 2005): 102-103.

\_\_\_\_\_. "Pivoting the Bow." *The Strad* 115, no. 1365 (January 2004): 65.

\_\_\_\_\_. "Playing into the Wood of the Bow." *The Strad* 118, no. 1401 (January 2007): 66-67.

\_\_\_\_\_. "Playing on Soundpoints." *The Strad* 118, no. 1410 (October 2007): 79.

\_\_\_\_\_. *Practice: 250 Step-by-Step Practice Methods for the Violin*, edited by Hinrichsen. London: Peters Edition, 2004.

\_\_\_\_\_. "Right-Hand Sensitivity." *The Strad* 119, no. 1422 (October 2008): 112-113.

\_\_\_\_\_. "Some Essential Aspects of the Bow and Bow Arm." *The Strad* 106, no. 1264 (August 1995): 800.

\_\_\_\_\_. "Soundpoint Exercises." *The Strad* 107, no. 1272 (April 1996): 404.

\_\_\_\_\_. "Technique and Ease in Violin-Playing." 16-22 in *The Musician's Hand*, edited by Ian Winspur and C. B. Wynn Parry. London: Taylor & Francis Group, 1998.

- \_\_\_\_\_. "The Bow: Thumb Counter-Pressure." *The Strad* 103, no. 1226 (June 1992): 498.
- \_\_\_\_\_. "Tone Production." *The Strad* 116, no. 1385 (September 2005): 92-93.
- \_\_\_\_\_. "Tone Production." *The Strad* 119, no. 1420 (August 2008): 76-77.
- \_\_\_\_\_. "Tone and Point of Contact." *The Strad* 118, no. 1411 (November 2007): 93-93.
- Flesch, Carl, *The Art of Violin Playing: Book II, Artistic Realization and Instruction*. edited by Eric Rosenblith. New York: Carl Fischer, 1930.
- \_\_\_\_\_, *Problems of Tone Production in Violin Playing*. Translated by Gustav Saenger, edited by Gustav Saenger. New York: Carl Fischer, 1931. (revised 1934).
- \_\_\_\_\_, *The Art of Violin Playing: Book I*. edited by Eric Rosenblith. New York: Carl Fischer, 2000.
- Fletcher, Neville Horner and Thomas D. Rossing. *The Physics of Musical Instruments*. CA: Springer-Verlag, 1998.
- Gabrielsson, Alf and Eric E. V. Jansson. "An Analysis of Long Time-Average-Spectra of Twenty-Two Quality-Rated Violins." 20-34 in *Music and Hearing Quarterly Progress and Status Report 17*. Stockholm: Royal Institute of Technology (KTH). (February/March 1976). <http://www.speech.kth.se/publications/> .
- Galamian, Ivan. *Principles of Violin Playing and Teaching*. 3<sup>rd</sup> edition, Ann Arbor, MI: Shar Products Co., 1985.
- Galluzzo, Paul. *Notes on Various Engineering Subjects*. Cambridge, UK: University of Cambridge, Dynamics & Vibration Research Group. [http://www2.eng.cam.ac.uk/~pmg26/home\\_frame.html](http://www2.eng.cam.ac.uk/~pmg26/home_frame.html) .
- Gerle, Robert. *The Art of Bowing Practice: The Expressive Bow Technique*. London: Stainer & Bell, 2004.
- Gough, Colin. "Science and the Stradivarius." *Acoustical Society of America* 4 (April 2000). <http://physicsworld.com/cws/article/print/696> .
- Grey, John M. "Multidimensional Perceptual Scaling of Musical Timbres." *Acoustical Society of America* 61, no. 5 (May 1977): 1270-1277.

- Guettler, Knut. *The Bowed String: On the Development of Helmholtz Motion: On the Creation of Anomalous Low Frequencies*. Royal Institute of Technology, 2002.
- Hamann, Donald L. and Robert Gillespie. *Strategies for Teaching Strings: Building a Successful String and Orchestra Program*. New York: Oxford University Press, 2004.
- Heeger, David. *Linear Systems Theory*. New York: New York University, 2000.  
<http://www.cns.nyu.edu/~david/handouts/linear-systems/linear-systems.html>.
- Helmholtz, Hermann von. *On the Sensation of Tone as a Physiological Basis for the Theory of Music*. Translated Alexander John Ellis, 4<sup>th</sup> edition. New York: Longmans, Green, Doves, 1912.
- Ho, Tracy Kwei-Liang. "The Development of a Computer-Assisted Approach to the Teaching of Violin Tone Production." PhD diss., Columbia University Teacher's College, 1990.
- \_\_\_\_\_, "Method and Apparatus for Teaching the Production of Tone in the Bowing of a Stringed Instrument." United States Patent #5038662, (August 1991).  
<http://www.patentgenius.com/patent/5038662.html> .
- Hsieh, Andrew. "Cremona Revisited: The Science of Violin Making." *Engineering & Science* no. 4 (April 2004): 28-35.
- Huffman, Carl. "Pythagoras." *Stanford Encyclopedia of Philosophy*, edited by Edward N. Zalta. Stanford, CA: Center for the Study of Language and Information, 2005.
- Hutchins, Carleen M. "Introduction." 2-5 in *The Physics of Music*. edited by Carleen Hutchins. San Francisco: Scientific American with W. H. Freeman and Co., 1978.
- Hutchins, Carleen M. and Duane Voskuil. "Mode Tuning For the Violinmaker." *Catgut Acoustical Society Journal* 2, no. 4 Series II (November 1993): 5-9.  
<http://www.catgutacoustical.org/research/articles/modetune/>.
- Immersion Corporation. *What is Haptics*. (San Jose, CA: Immersion Corporation, 2008),  
[http://www.immersion.com/corporate/press\\_room/what\\_is\\_haptics.php](http://www.immersion.com/corporate/press_room/what_is_haptics.php) .
- Jansson, Eric. "Admittance Measurements of 25 High Quality Violins." *Journal of the Acoustical Society of America* 83, no 2 (March 1995): 337-341.

- \_\_\_\_\_. “The Tone and Tonal Quality of the Violin” chapter 8 in *Acoustics for Violin and Guitar Maker*. Stockholm: Royal Institute of Technology (KTH), 2002.  
<http://www.speech.kth.se/music/acvguit4/part8.pdf> .
- Jeung, Albert Yiu. “Class Fundamentals for Strings: A Supplementary Method Book for Intermediate String Orchestra.” MM thesis, California State University 1999.
- Lui, Kexi. “Teaching the Basic Violin Bowing Technique: A Comparative Study of the Bowing Technique of Selected Violin Schools from 1751-1974.” DMA diss., University of North Carolina, Greensboro, 1993.
- Marsh, Peter. “Some Thoughts on the Teaching of Violin.” *American String Teacher* 37, no. 3 (Summer 1988), 68-69.
- Marshall, Kenneth D. “Modal Analysis of a Violin.” *Acoustical Society of America* 77 (February 1985): 695-709.
- McLennan, John. “The Art, History and Science of Violin Making.” lecture Department of Mechanical Engineering, University of Newcastle, Australia (August 1993).  
<http://www.phys.unsw.edu.au/music/publications/mclennan/arthistoryscience.pdf> .
- Mejia, Paloma Y. “How Does a Violin Make Sound?” 137-140 in *Engineering Acoustics* (April 2006). <http://www.scribd.com/doc/334613/engineering-acoustics> .
- Moravec, Ondřej and Jan Štěpánek. “Verbal Description of Musical Sound Timbre in Czech Language.” in *Proceedings of the Stockholm Music Acoustics Conference*. Stockholm, Sweden (August 2003). <http://zvuk.hamu.cz/studio/dokumenty/Lit96.pdf> .
- Nichols, Charles Sabin II. “The Vbow: A Virtual Violin Bow Controller for Mapping Gesture to Synthesis with Haptic Feedback.” *Organized Sound* 7, no. 2 (2002): 215-220. <http://www.charlesnichols.com/> .
- \_\_\_\_\_, “The Vbow: An Expressive Musical Controller Haptic Human-Computer Interface on the Role of Longitudinal String Vibrations.” PhD diss., Stanford University, 2003.
- Paradiso, Joseph A., and Neil Gershenfeld. “Musical Applications of Electric Field Sensing Physics.” *Computer Science Journal* (April 1996): 12.

- Perez, Alfonso, Jordi Bonada, Esteban Maestre, Enric Guaus, Merlijn Blaauw. "Combining Performance Actions with Spectral Models for Violin Sound Transformation." conference paper, *19<sup>th</sup> International Congress on Acoustics*. Madrid: Music Technology Group (September 2007): 1-6. <http://mtg.upf.edu/files/publications/93f0a2-ICA-2007-perez.pdf> .
- Pitteroff, Roland and Jim Woodhouse. "Mechanics of the Contact Area between a Violin Bow and a String, Part III: Parameter Dependence." *Acta Acustica United with Acustica* 84 (May 1998): 929-946.
- Pollens, Stewart. "Curtains for Cremona." *The Strad* 106, no. 1267 (November 1995): 1160.
- Pratt, David. "Patterns in Nature Part II: Chladni Plates." *Our World on CompuServe* (January 2006). <http://ourworld.compuServe.com/homepages/DP5/pattern2.htm#p1> .
- Previn, Andre. *No Minor Keys: My Days in Hollywood*. New York, Doubleday, 1993.
- Raman, Chandrasekhara Venkata "The Dynamical Theory of the Motion of Bowed Strings." *Bulletin of the Indian Association for the Cultivation of Science* 11 (1914): 43-52. <http://hdl.handle.net/2289/2119> .
- \_\_\_\_\_. "Experiments with Mechanically-Played Violins." *Proceedings of the Indian Association for the Cultivation of Science*. Bangalore: Indian Academy of Sciences 6 (1920): 19-36. <http://hdl.handle.net/2289/2167> .
- \_\_\_\_\_. "On the Mechanical Theory of the Vibrations of Bowed Strings and of Musical Instruments of the Violin Family, with Experimental Verification of the Results, Part I." *Bulletin of the Indian Association for the Cultivation of Science*. 15 (1918): 1-158. <http://hdl.handle.net/2289/2118> .
- Rasamimanana, Nicolas Hainiandry. "Gesture Analysis of Bow Strokes Using an Augmented Violin." MS thesis, Paris: University Pierre and Marie Curie, 2004.
- Rossing, Thomas D. "Chladni's Law for Vibrating Plates." *American Journal of Physics* 50, no. 3 (March 1981). 271-274.
- Saunders, Frederick A. "Physics and Music." 6-15 in *The Physics of Music*. edited by Carleen Hutchins. San Francisco: Scientific American with W. H. Freeman and Co., 1978.

- Schelleng, John S. "The Physics of the Bowed String." 69-77 in *The Physics of Music*. edited by Carleen Hutchins. San Francisco: Scientific American with W. H. Freeman & Co., 1978.
- \_\_\_\_\_. "The Bowed String and the Player." *Acoustical Society of America* 53, no. 1 (January 1973): 26-41.
- Schleske, Martin. *Violin Acoustics Handbook: Criteria for Rating the Sound Quality of Violins*. Belgium: European Union, 2004. [www.schleske.com](http://www.schleske.com) .
- \_\_\_\_\_. "Zeitgeist and Violinmaking: Milestones of Art and Science - a Brief Journey through Time." lecture *100th anniversary of the founding of the Verband Deutscher Geigenbauer (Association of German violinmakers.)* Wiesbaden, Germany, (May 2004). <http://www.schleske.de/index.php?id=38&type=123&L=2> .
- Schmidt, Stan. *Old Versus New in Cello Testing: The New and Improved Cello Test* Elmhurst Illinois, 1991. <http://www.fritz-reuter.com/DOC/articles/other/oldvsnew.htm> .
- Schoonderwaldt, Erwin, Knut Guettler, and Anders Askenfelt. "Effects of the Width of the Bow Hair on the Violin String Spectrum." 91-94 in *Proceedings of the Stockholm Music Acoustics Conference*, Stockholm, Sweden, 2003. <http://www.speech.kth.se/publications/> .
- \_\_\_\_\_. "Schelling in Retrospect - A Systematic Study of Bow Force Limits for Bowed Violin Strings." in *Proceedings of the International Symposium on Musical Acoustics*, 2007. <http://www.speech.kth.se/publications/> .
- Schumacher, R. T. and Jim Woodhouse. "Computer Modelling [sic] of Violin Playing." *Contemporary Physics* 36, no. 2 (March 1995): 79-92.
- Serafin, Stefania. "The Sound of Friction: Real-Time Models, Playability, and Musical Applications." PhD diss., Stanford University, 2004.
- Serafin, Stefania and Diana Young. "Playability Evaluation of a Virtual Bowed String Instrument." 104-108 in *Proceedings of the 2003 Conference on New Interfaces for Musical Expression*. Montreal, Canada, 2003. [http://opera.media.mit.edu/papers/YoungSerafin\\_NIME03.pdf](http://opera.media.mit.edu/papers/YoungSerafin_NIME03.pdf) .

- Serafin, Stefania and Julius O. Smith III. *Influence of Attack Parameters on the Playability of a Virtual Bowed String Instrument*. Stanford, CA: Stanford University, 2000.
- \_\_\_\_\_. "A Multi-Rate, Finite-Width, Bow-String Interaction Model." 1-4 in *COST G-6 Conference on Digital Audio Effects*. Verona, Italy: Stanford University, 2000. [http://profs.sci.univr.it/~dafx/Final-Papers/pdf/Serafin\\_Stefania\\_paper.pdf](http://profs.sci.univr.it/~dafx/Final-Papers/pdf/Serafin_Stefania_paper.pdf).
- \_\_\_\_\_. *Impact of String Stiffness on Virtual Bowed Strings*. Stanford, CA: Stanford University, 2002.
- Shirley, Paul. "Right Hand Culture for Violin, Viola and Cello Players." New York: Carl Fischer, 1917.
- Smith, Roland A and D.M.A. Mercer. "Recent Work on Musical Acoustics." *Reports on Progress in Physics* 42 (July 1979): 1085-1129.
- Štěpánek, Jan. "Evaluation of Timbre of Violin Tones According to Selected Verbal Attributes." 129-132 in *The 32nd International Acoustical Conference*. Slovakia, 2002.
- \_\_\_\_\_. "Musical Sound Timbre: Verbal Description and Dimensions." 121-126 in *Proceedings of the 9<sup>th</sup> Conference on Digital Audio Effects*. Montreal, Canada: Musical Acoustics Research Centre Prague, 2006. [http://www.dafx.ca/proceedings/papers/p\\_121.pdf](http://www.dafx.ca/proceedings/papers/p_121.pdf).
- Štěpánek, Jan, and Zdeněk Otčenášek. "Listener Common and Group Perceptual Dimensions in Violin Timbre." 663-666 in *Stockholm Music Acoustics Conference*. Stockholm, Sweden, 2003.
- \_\_\_\_\_. "Rustle as an Attribute of Timbre of Stationary Violin Tones." *Catgut Acoustical Society Series II* 3, no. 8 (November 1999): 32-38.
- Stöckmann, Hans-Jürgen. "Chladni Meets Napoleon." *European Physics Journal Special Topics* 145 (June 2007): 15-23.
- Stowell, Robin. "Principle Violin Pedagogy through the Ages 6: Galamian and Fischer." *The Strad* 119, no. 1414 (February 2008): 58-63.
- Suzuki, Shinichi. *Suzuki Violin School: Book I*. Van Nuys, CA: Alfred Publishing, 1978.

- Todes, Adriane. "Teaching the Teachers." *The Strad* 118, no. 1409 (September 2007): 27-30.
- Topper, Matson Alan. "Correcting the Right Hand Bow Position for the Student Violinist and Violist." DA diss., Florida State University, 2003.
- Villaret, Amada Louise. "The Franco-Belgian and Russian Methods of Bowing: A Pedagogic Study." DA diss., Ball State University, Muncie, 1988.
- Wolfe, Joe and John Smith. *Bows and Strings*. Sydney, Australia: The University New South Wales. <http://www.phys.unsw.edu.au/jw/Bows.html>.
- Wood, Alexander. *The Physics of Music*. 6<sup>th</sup> edition, revised J.M. Bowsher. New York: Dover Publications, 1962.
- Woodhouse, Jim. "On the Playability of Violins Part I: Reflections, Functions, Part II: Minimum Bow Force and Transients." *Acustica* 78 (1993): 125-153.
- Woodhouse, Jim, Ian Cross, Brian C. J. Moore, and Claudia Fritz. "Perceptual Tests with Virtual Violins." 615-622 in *Proceedings of the Institute of Acoustics*. London: University of Cambridge, 2006.
- Woodhouse, Jim and Paul Galluzzo. "Why Is the Violin So Hard to Play?" +*Plus Magazine* 31, no. 9 (September 2004). <http://plus.maths.org/issue31/features/woodhouse/index.html#observe> .
- Young, Diane. "New Frontiers of Expression through Real-Time Dynamics Measurement of Violin Bows." MS thesis, MIT, 2001.
- \_\_\_\_\_. "A Methodology for Investigation of Bowed String Performance through Measurement of Violin Bowing Technique." PhD diss., MIT, 2007.
- Young, Diana, and Anagha Deshmane. "Bowstroke Database: A Web-Accessible Archive of Violin Bowing Data." 352-357 in *Proceedings of the 7<sup>th</sup> International Conference on New Interfaces for Music Expression*. New York Association for Computing Machinery, 2007.
- Young, Diana, Patrick Nunn, and Artem Vassiliev. "Composing for Hyperbow: Collaboration between MIT and the Royal Academy of Music." 296-401 in *2006 Conference on New Interfaces for Musical Expression*. Paris, France, 2006.

Young, Phyllis. *The String Play: The Drama of Playing and Teaching Strings*.  
Austin, TX: University of Texas Press, 1986.

## CURRICULUM VITAE

Dr. Cheri Collins graduated from the Manhattan School of Music in New York City, where she earned a Bachelor of Performance on violin. While attending the Manhattan School of Music on full scholarship, she was one of two freshmen chosen that year to study with the Russian-born violin professor, Raphael Bronstein. Dr. Collins pursued her career as an orchestral performer, playing in the first violin sections of the São Paulo Symphony in São Paulo, Brazil and then the Florida Orchestra in Tampa, Florida (formally the Florida Gulf Coast Symphony). She moved to Northern Virginia to begin a varied and successful freelance career. Since 1990, Dr. Collins has focused on her passion for teaching; she is presently the orchestra director at Oakton High School in Oakton, Virginia, and conductor for the American Youth Philharmonic String Ensemble. Dr. Collins' orchestras receive "Superior" ratings at Orchestra Festivals, as well as subsequent state and national competitions, receiving outstanding recognitions from Virginia Music Educators Association, American String Teachers Association, National America Orchestra Festival, and more. She is a string adjudicator for District Festivals throughout Virginia and recently is in demand as clinician, presenting her *New Method* of teaching good tone-production to students and directors.